

BMM WESTON

Sterilizers

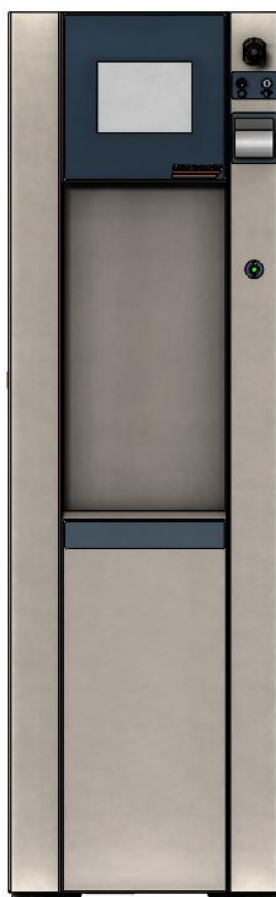

INSTALLATION & MAINTENANCE MANUAL POROUS LOAD Series 1

AB3067 Rev. 2 20/04/2023
Original Instructions

BMM WESTON LTD, WESTON WORKS, FAVERSHAM, KENT, ENGLAND

Head Office: Phone 01795 533441 Fax 01795 538891 Email: mail@bmmweston.com Website: www.bmmweston.com
Service Dept: Phone 01795 597127 Fax 01795 538891 Email: service@bmmweston.co.uk

Contents

Safety Notice and Symbols	5
Safety Instructions	6
Operating the Sterilizer	6
Loading and Unloading the Sterilizer	6
Processed Items and Cycles	7
Door Operation	7
End of Cycle	7
Environmental Considerations	7
Maintenance and Management	8
Disposal Instructions.....	8
Intended Use	9
Personnel	9
Packaging.....	10
Handling	10
General Information.....	11
Hardware	11
EMC – Radiated Emissions	13
EMC – Susceptibility	14
Siting	14
Services.....	15
Electrical	15
Steam	15
Drain	16
Water	16
Air	16
Safety Valves.....	17
Safety Valve Testing.....	17
Installation Checks	20
1. Service Checks	20
2. Door Checks	20
3. Pump Checks	20
4. Maintenance Menu Checks	21
5. Electrical Checks	21
Insulation Resistance Test.....	22
Bonding and Earth Continuity.....	23
Installation Checklist.....	25
Validation.....	26
Loading Shelves.....	27
Loading Trolley Adjustment	28
Maintenance Programme	29
Safety Procedures	29
Daily Maintenance	29
Quarterly Maintenance.....	30
Yearly Maintenance	31
Replacement Parts Checklist	31
Maintenance Schedule – Daily and Weekly	32
Maintenance Schedule – Quarterly and Yearly.....	33
Door Auto/Manual Switch	34
Door Seal	34
Door Maintenance	35

CONTENTS

Door Movement	35
Door Sealing and Unsealing	36
Door Supports.....	36
Guide Rollers	36
Door Cylinder	36
Limit Switches.....	36
Pressure Interlocks	36
Door Switches.....	37
Calibration	38
Temperature Channels.....	38
Pressure Channels	39
In-Cycle calibration of temperature and pressure channels	40
Printer.....	42
Printer configuration.....	44
Integral Electrical Steam Generators.....	45
Integral Generator Operation.....	46
Replacement and checking of Heater Elements	47
Boiler Radar Assembly.....	48
Safety Valve and Overpressure checks	48
Steam Generator Control Menus	49
Drawings and Parts List.....	50
Valve Island & Air Preparation Set.....	50
Control Valves - SMC	52
Strainers	53
Pressure Switches.....	54
Steam Trap.....	55
Tri-clamp Seals.....	56
O – Ring Seals	56
Recommended Spares.....	57
Contacts	58

THIS MANUAL CONTAINS INFORMATION FOR SAFE INSTALLATION, TESTING AND VALIDATION OF THE STERILIZER.

Safety Notice and Symbols



Warning Symbol – Black exclamation mark symbol on a yellow background contained within a black triangular band. This symbol is included on the sterilizer label indicating that accompanying documents must be consulted before operating the sterilizer in order to find out the nature of the potential hazards and any actions which have to be taken to avoid them. Particular attention should be paid to the safety instructions section and the caution and warning statements contained throughout the manual.

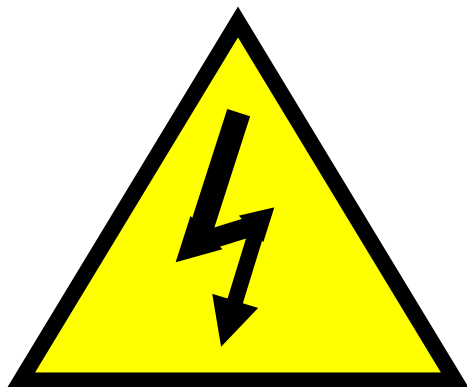

Electric Flash Hazard Symbol – Black flash symbol on a yellow background contained within a black triangular band.

Sign attached to the covers and lids of all electrical enclosures, junction boxes and operator control panel. Indicates a warning to personnel that an electrical hazard will be present on the removal of the cover, lid or panel. Only qualified maintenance and test engineers should be

WARNING - ALL PERSONS INVOLVED IN THE INSTALLATION, TESTING AND VALIDATION OF THE STERILIZER SHOULD HAVE APPROPRIATE TRAINING IN THESE TASKS. ALL PERSONS INVOLVED SHOULD READ AND BECOME ACQUAINTED WITH THE SECTION ENTITLED 'SAFETY INSTRUCTIONS' CONTAINED WITHIN THIS MANUAL.

Safety Instructions

NOTES, CAUTIONS, and WARNINGS are used in the manual to draw attention to important work and safety practices:

NOTE –	A NOTE IS USED TO DRAW ATTENTION TO AN INSTRUCTION THAT IS NOT DIRECTLY RELATED TO PERSONNEL SAFETY OR DAMAGE TO THE MACHINE.
CAUTION -	A CAUTION IS USED TO INDICATE A HAZARDOUS SITUATION THAT MAY RESULT IN INJURY TO PERSONNEL OR DAMAGE TO THE MACHINE.
WARNING -	A WARNING IS USED TO INDICATE A HAZARDOUS SITUATION WHICH HAS SOME PROBABILITY OF LEADING TO DEATH OR SERIOUS PERSONAL INJURY.

WARNING – READ THE FOLLOWING INSTRUCTIONS CAREFULLY BEFORE ANY ATTEMPT IS MADE TO OPERATE THE STERILIZER OR WHEN FIRST PLACING THE STERILIZER INTO USE.

The following instructions should be carried out in order to ensure that the sterilizer is operated safely, and that maintenance and validation tasks are undertaken at regular intervals to ensure that the sterilizer continues to function safely and that products are processed satisfactorily.

Operating the Sterilizer

WARNING – All operators should be given appropriate training in use of the sterilizer. If coded access to the sterilizer is used, each operator should be given a code to access only those functions and operations they are authorized to use. Training should be ongoing and reviewed regularly. Training records should be documented.

WARNING – All maintenance work should be documented in a maintenance log book. Details of the work completed, the date and the name of the engineer/s should be recorded

WARNING – If the equipment is used in a manner not specified in this manual, the protection provided by the equipment may be impaired.

CAUTION - Do not touch any part of the sterilizer chamber or door. These parts are likely to be hot and could cause burns if touched without wearing heat protective clothing and gloves.

WARNING – Do not enter or partially enter the sterilizer chamber without first obtaining the key for the control panel auto/manual door switch and then turning the switch to the manual position. With the switch in the manual position, remove the key and keep on your person until it is safe to return the switch to the auto position and for normal operation of the sterilizer to resume.

CAUTION – All sterilizer keys should be held in safe and secured storage. The issuing of keys should be authorised by the person/s responsible for their safe storage.

CAUTION – After use, the key should not be left in the door auto/manual key switch. The key should be returned to the person/s responsible for the safe storage of the sterilizer keys.

WARNING – The machine should not be operated if any of the test cycles give an unsatisfactory result. The Bowie and Dick cycle indicates the effectiveness of air removal from, and steam penetration into the load. The Leak Rate Test cycle indicates when air leaks into the chamber are above specified limits. The LRT will also indicate, and provide a warning, if the vacuum attained in the chamber does not reach a specified depth, typically 60mbarA or below.

WARNING – An electrical power disconnection device (isolator) is sited in the plantroom area. This should be turned off and locked if work of a hazardous nature is to be performed on the sterilizer.

Loading and Unloading the Sterilizer

CAUTION - Always wear heat protective gloves when handling, removing, or partially removing load carriers or shelves from the sterilizer chamber. Load carriers, shelves and load items are likely to be hot and could cause burns if touched without wearing heat protective gloves.

CAUTION – When transferring a load carrier from the sterilizer chamber onto a trolley, or from the trolley into the chamber, always ensure that the trolley locking device is engaged to the sterilizer chamber locking plate.

CAUTION – Do not overload the loading carriage. This may give rise to excessive effort being required to maneuver the trolley and to transfer the loading carriage on and off the trolley.

Processed Items and Cycles

CAUTION – Articles to be sterilized should be presented to the sterilizer in a clean state in order to reduce bioburden levels. For guidance on bioburden, refer to EU standards BS EN 17665 and EN556.

CAUTION – Heat sensitive items unable to withstand the sterilizing temperatures of cycles fitted to the sterilizer, should not be processed in the sterilizer. If in any doubt as to the suitability of the sterilizing cycle, seek advice from the person responsible for the sterilizer. Advice from the manufacturer of the item may need to be obtained.

CAUTION – Fluids, in sealed or unsealed containers, must not be processed in sterilizers and sterilizing cycles designed solely for processing medical devices. Hot fluids can cause an explosion hazard.

Door Operation

CAUTION – When the Sterilizer door is closing keep clear to avoid entrapment.

CAUTION – Before closing the sterilizer door ensure that no load carrier, shelf or load item protrudes from the chamber. Failure to do so may result in damage to the protruding article.

CAUTION – When opening or closing the sterilizer door, ensure that the loading trolley or shelf is clear of the moving door. Failure to do so may result in damage to the sterilizer panelwork.

Caution – Do not allow articles to be sterilized to overhang the sides of a load carrier or shelving system. Articles or their packaging may be damaged when they are being transferred into or out of the sterilizer, and this may affect their sterile condition after removal from the sterilizer.

End of Cycle

WARNING – Always check the printed sterilizer cycle log and the user display at cycle end to confirm that the cycle was a pass cycle and the cycle was appropriate for the sterilization of the items processed.

WARNING - Never release goods for use from a failed cycle – all goods should be reprocessed to achieve sterilization.

WARNING – If a fault condition message appears on the operator message screen, report fault condition to person/s responsible for the sterilizer so that appropriate action can be taken in determining the reason/s for the fault.

Environmental Considerations

CAUTION – This sterilizer has been tested and conforms to the requirements of EN 61000 standard on Electromagnetic Compatibility. If the sterilizer is sited in an area where the limits of electromagnetic radiation, applied by this standard, are likely to be exceeded, i.e. close to X-ray or magnetic resonance imaging equipment, advice should be obtained from the manufacturers of both the sterilizer and the high electromagnetic source equipment.

CAUTION – Peripheral equipment connected to the sterilizer external ports i.e. data collection computers, must conform to BS EN 60950 – Specification for safety of information technology equipment, including electrical business equipment.

CAUTION – The Sterilizer should be operated in a local environment where the temperature does not exceed 40°C and the relative humidity does not exceed 80%.

CAUTION – For the operator screens to be read and operated correctly, the screen should not be subject to direct sunlight or other bright light sources.

CAUTION – Adequate lighting should be provided in the plantroom and the operator work area to enable indicators and gauges to be readable (by normal or corrected vision) from a distance of 1 m at any external illumination level in the range of (215 ± 15) lx to (1 500 ± 15) lx.

Maintenance and Management

WARNING – Before any attempt is made to work on the sterilizer, ensure that all services to the machine are isolated and, where appropriate, locked and that any pressure retaining parts are safely reduced to atmospheric pressure.

WARNING – The installation of the sterilizer should only be undertaken by suitably trained and skilled personnel. The installation procedures and checks should be documented to demonstrate that the sterilizer is safe to use and has been installed to specification.

WARNING – A scheme of inspection for the safety of the sterilizer pressure vessel and door should be instituted. A Competent Person for the inspection of pressure vessels should be appointed.

WARNING – After installation, the sterilizer should be commissioned and validated to demonstrate that the sterilizer, as installed, is safe to use and operates to specification. This is a documented procedure, and should be undertaken by suitably qualified personnel.

WARNING – In use, the sterilizer should be periodically maintained and tested to ensure that it continues to function safely and that its performance continues to be within specification. This is a documented procedure, and should be undertaken by suitably qualified personnel.

WARNING – The safe state of the equipment must be verified after any repair.

NOTE – For the management of sterilizers see the requirements detailed in Department of Health guidance note Choice Framework for local Policy and Procedures 01-01, Parts A, B and C

Disposal Instructions

According to the WEEE Directive 2002/96/EC, all categories of electrical and electronic equipment (EEE) covered by this directive in the ANNEX IA should be disposed of and collected separately and use the best available treatment, recovery and recycling techniques.

EEE contains hazardous substances to the human health and environment but EEE is also a valuable resource of raw materials. Therefore it is important to collect WEEE separately from other wastes.

BMM Weston sterilizers are subject to the Directive and we therefore urge you to dispose of the equipment separately from 'normal' household waste and make sure that it is properly treated, recovered or recycled to protect human health and the environment.

Sterilizer packaging (wooden crate, plastic wrapping etc.) should be disposed of in the same manner as conventional waste of the same material.



Applies to Electrical Control system fitted to Sterilizer

The symbol shown here means that the product is classed as Electrical or Electronic Equipment and should not be disposed with other household or commercial waste at the end of its working life.

The Waste of Electrical and Electronic Equipment (WEEE) Directive (2002/96/EC) has been put in place to recycle products using best available recovery and recycling techniques to minimize the impact on the environment, treat any hazardous substances and avoid increasing landfills.

Contact your local authority or the nearest collection site to dispose of Electrical and Electronic Equipment waste.

For disposal of entire sterilizer (end-of-life) contact BMM Weston for recommendations.

Intended Use

For a description of the Intended Use and operation of the sterilizer please refer to the separate User Manual issued with the sterilizer.

The efficacy of the sterilization process cannot be verified retrospectively by examination or testing of the product before it is used. It is for this reason that the sterilization process is initially validated, the performance routinely monitored by a scheme of periodic testing, and the machine subject to a programme of planned preventative maintenance.

Personnel

The persons involved in the periodic testing and maintenance of the sterilizers are defined in CFPP 01-01 Management and decontamination of surgical instruments: Part B – Common elements.

Packaging

The sterilizer will be delivered with packaging that offers suitable protection during transportation to site. This will differ in form according to the type of transport used and to whether the sterilizer is to be installed immediately or a period of storage is planned before installation.

In instances where the sterilizer is covered with shrink wrap polythene sheeting, this protective sheeting should remain in place until the sterilizer has been moved to its installed position and installation is about to commence. This will afford protection to the sterilizer panel work and sterilizer components whilst moving the machine to the installed position.

CAUTION – IF THE STERILIZER IS TO BE STORED FOR ANY PERIOD OF TIME BEFORE INSTALLATION, OR IF IT IS TO BE INSTALLED IN AN AREA WHERE CONSTRUCTION WORK IS STILL IN PROGRESS, THE STERILIZER SHOULD BE SUITABLY PROTECTED FROM PHYSICAL AND ENVIRONMENTAL DAMAGE.

Handling

If the sterilizer is delivered on a pallet, both can be moved by means of a forklift.

WARNING – ENSURE THAT THE LIFTING CAPACITY OF THE FORKLIFT, OR ANY OTHER LIFTING DEVICE THAT MAY BE EMPLOYED, IS ADEQUATE FOR LIFTING THE STERILIZER. REFER TO THE WEIGHT OF THE STERILIZER ON GENERAL ARRANGEMENT (GA) DRAWING IN THE BACK OF THIS MANUAL.

WARNING – IF A FORKLIFT IS USED TO LIFT THE STERILIZER, EITHER WHEN ON A PALLET OR FROM BENEATH THE STERILIZER LIFTING POINTS, ENSURE THAT THE FORKS ARE POSITIONED AS WIDELY AS POSSIBLE FOR MAXIMUM LOAD STABILITY.

To lift the sterilizer from a transport pallet, remove any securing straps or blocking that may secure the sterilizer to the pallet, and then place the forklift forks under the horizontal structural bars connected between the vertical sterilizer support columns. Refer to GA showing the forklift forks positioned below the horizontal lifting bars.

The sterilizer can also be lifted by means of the lifting points attached to the top of the sterilizer chamber. Remove any securing straps or blocking that may secure the sterilizer to the pallet before lifting the sterilizer.

WARNING – IF THE CHAMBER LIFTING POINTS ARE USED, ALWAYS USE THE 4 LIFTING POINTS. THE CHAIN, OR LIFTING MEMBERS, SHOULD BE OF EQUAL LENGTH WITH AN ANGLE TO THE HORIZONTAL NOT LESS THAN 45 DEGREES.

When the transport pallet has been removed, or if the sterilizer has been supplied without a transport pallet, the sterilizer can either be moved by means of a forklift or a pallet truck by lifting the sterilizer under the horizontal lifting bars.

If access to the point of installation is restricted, the front panel assembly can be removed to narrow the width of the machine. A site survey would normally have been conducted before the sterilizer has been dispatched to site, and the necessary preparations made for the easy removal of the fascia assembly. If the sterilizer has been prepared for the removal of the fascia assembly, remove the panels situated above and below the door. The remaining side panels can now be removed by removing the screws from the top and bottom of the panel (The VDU/Touchscreen to remain in the large panel). Handle all panels with care to avoid damage to panels & VDU/Touchscreen.

The door retaining/slide bars can now be removed by removing the 4 (2 on top bar, 2 on bottom bar) M20 cap head screws. **On reassembling the bars, these screws must be fastened to a torque of 480Nm.**

WARNING – BEFORE REMOVING THE UPPER AND LOWER DOOR RETAINING/SLIDE BARS, ENSURE THAT THE DOOR IS ADEQUATELY SECURED. ON REFITTING THE BARS, THE RETAINING CAP HEAD SCREWS MUST BE TORQUED TO 480NM.

If the sterilizer has not been prepared for the removal of the fascia assembly, but the fascia assembly removal is required, proceed as follows:-

- a) Disconnect the electrical cables from the back of the VDU/Touchscreen, key switch, e-stop and printer.
- b) Remove the panels as described above.

General Information

Hardware

INSTALLATION CATEGORY II	Designed to conform to BS EN 61010-1:2010 + A1:2019 and BS EN 61010-2-040:2015
POLLUTION DEGREE 2	Designed to conform to BS EN 61010-1:2010 + A1:2019 and BS EN 61010-2-040:2015
TEMPERATURE INPUTS	<p>Up to two resistance measurement temperature inputs with constant current supply for 2-wire connection temperature inputs. These have a 13-bit resolution with a range of -200°C to 850°C. Connection must be a PT1000 RTD Sensor. Temperature sensor resolution = 0.16°C and resistance measurement resolution = 0.49 ohms.</p> <p>Up to seven resistance measurement temperature inputs with constant current supply for 2 or 3 wire connections. These have a 16-bit resolution with a range of -200°C to 850°C. Connection can be either a PT100 or a PT1000 RTD Sensor. Temperature sensor resolution = 0.1°C and resistance measurement resolution = 0.05 – 0.1 ohms.</p>
PRESSURE INPUTS	<p>Up to six analog inputs ± 10 V or 0 to 20 mA / 4 to 20 mA, via different terminal connections (selectable) with a configurable input filter. Range 0-4000mbarA. Resolution 1mbar, Out of range error detection. Accuracy better than $\pm 0.5\%$ over pressure range. Ambient temp. error compensation $\pm 0.015\%/K$ over range.</p>
DIGITAL OUTPUTS	<p>56 digital outputs with a 0.5A nominal output current and 24V nominal output voltage. FET Positive switching with LED indication and diagnostics. Thermal cutoff if overcurrent or short circuit occurs, internal inverse diode for switching inductive loads.</p> <p>6 relay outputs, normally open contacts, 240V AC @ 2A, 30V DC @ 2A, single channel isolation with LED indication and diagnostics.</p>
DIGITAL INPUTS	Up to 50 digital inputs with an input voltage of 24VDC with LED indication and diagnostics.
INTERFACES	2x RS232 2x Ethernet 3x USB 2x X2X Link, 1x CAN bus 1x POWER-LINK Used for networking between devices, connecting the printer and touchscreen.
PRINTER	Printing width 48mm, 58mm Paper Width.
DISPLAY	Power Panel T50, 10.1", glass front (anti-glare), 1x Gigabit Ethernet. CPU and memory: 800 MHz dual core (ARM Cortex-A9), 1 GB RAM, 512 MB onboard flash drive. Display and touch screen: 10.1", 1280 x 800 (WXGA) resolution, projected capacitive touch screen, multi-touch support, anti-glare glass front with black frame, landscape and portrait format configurable with software. Interfaces: 1x Ethernet 10/100/1000 Mbit/s, 2x USB 2.0. Client software: Integrated service page, VNC client, embedded web browser.

ENVIRONMENTAL

TEMPERATURE LIMITS	Ambient temperature operation: Horizontal Mounting : -25 to 60°C Vertical mounting : -25 to 50°
HUMIDITY LIMITS	Operation: 10 to 80% RH ; Storage: 5 to 80% RH
ALTITUDE LIMIT	< 2000 metres max.
USE ENVIRONMENT	Indoor use only

EMC

GENERAL REQUIREMENTS	BS EN 61326-1:2013
----------------------	--------------------

ELECTRICAL SAFETY

GENERIC SAFETY STANDARD	BS EN 61010-1:2010 + A1:2019
PRODUCT SAFETY STANDARD	BS EN 61010-2-040:2015
PERMISSIBLE MAINS SUPPLY VOLTAGE FLUCTUATION	±10%
OVERVOLTAGE CLASSIFICATION	CATEGORY II

PRODUCT STANDARD & RECOMMENDATIONS

DIRECTIVES	Directive 93/42/EEC – Medical Devices Directive 97/23/EC – Machinery Directive 97/42/EC – Pressure Equipment
STERILIZERS GENERAL	BS EN 285:2015 Large Steam Sterilizers PD5500:2018 – Unfired Pressure Vessels CFPP 01-01

GENERAL INFORMATION

EMC – Radiated Emissions

Table of typical radiated emissions over range 30 to 1000 MHz

Frequency (MHz)	QuasiPeak (dBµV/m)	Meas. Time (ms)	Bandwidth (kHz)	Polarization	Corr. (dB)	Margin (dB)	Limit (dBµV/m)	Comment
30.000000	46.6	2000.0	120.000	Vertical	18.3	3.4	50.0	*
33.690000	37.3	2000.0	120.000	Vertical	16.2	12.7	50.0	
34.860000	42.4	2000.0	120.000	Vertical	15.6	7.6	50.0	
37.740000	39.0	2000.0	120.000	Vertical	14.0	11.0	50.0	
41.385000	40.0	2000.0	120.000	Vertical	12.2	10.0	50.0	
44.265000	35.8	2000.0	120.000	Vertical	10.9	14.2	50.0	
47.460000	27.1	2000.0	120.000	Vertical	9.3	22.9	50.0	
49.035000	30.3	2000.0	120.000	Vertical	8.8	19.7	50.0	
55.920000	37.1	2000.0	120.000	Vertical	6.6	12.9	50.0	
60.420000	41.9	2000.0	120.000	Vertical	6.0	8.1	50.0	
60.600000	41.7	2000.0	120.000	Vertical	6.0	8.3	50.0	
64.965000	32.3	2000.0	120.000	Vertical	6.0	17.7	50.0	
73.695000	27.7	2000.0	120.000	Vertical	6.5	22.3	50.0	
76.800000	33.3	2000.0	120.000	Vertical	7.0	16.7	50.0	
80.085000	30.1	2000.0	120.000	Vertical	7.4	19.9	50.0	
89.085000	38.2	2000.0	120.000	Vertical	9.5	11.8	50.0	
91.290000	42.9	2000.0	120.000	Vertical	10.0	7.1	50.0	
98.760000	35.9	2000.0	120.000	Vertical	11.3	14.1	50.0	
106.050000	31.2	2000.0	120.000	Vertical	12.3	18.8	50.0	
118.875000	23.2	2000.0	120.000	Vertical	12.8	26.8	50.0	
127.560000	24.1	2000.0	120.000	Vertical	13.0	25.9	50.0	
134.850000	20.7	2000.0	120.000	Vertical	12.7	29.3	50.0	
139.710000	30.5	2000.0	120.000	Vertical	12.4	19.5	50.0	
141.330000	32.1	2000.0	120.000	Vertical	12.2	17.9	50.0	
153.120000	22.2	2000.0	120.000	Vertical	11.3	27.8	50.0	
160.005000	36.0	2000.0	120.000	Vertical	11.0	14.0	50.0	
166.980000	34.3	2000.0	120.000	Vertical	10.8	15.7	50.0	
180.030000	36.1	2000.0	120.000	Vertical	9.9	14.0	50.0	
190.020000	24.6	2000.0	120.000	Vertical	10.2	25.4	50.0	
207.705000	30.7	2000.0	120.000	Vertical	10.3	19.3	50.0	
239.160000	37.7	2000.0	120.000	Vertical	12.6	19.3	57.0	
259.680000	23.4	2000.0	120.000	Vertical	14.7	33.6	57.0	
275.160000	22.6	2000.0	120.000	Vertical	14.3	34.4	57.0	
300.000000	34.6	2000.0	120.000	Vertical	14.9	22.4	57.0	
309.855000	24.9	2000.0	120.000	Vertical	15.3	32.1	57.0	
342.840000	24.0	2000.0	120.000	Vertical	16.2	33.0	57.0	
352.470000	39.4	2000.0	120.000	Vertical	16.5	17.6	57.0	
416.370000	26.1	2000.0	120.000	Vertical	18.8	30.9	57.0	
443.910000	36.8	2000.0	120.000	Vertical	18.6	20.2	57.0	
470.910000	39.2	2000.0	120.000	Vertical	19.2	17.8	57.0	
490.800000	26.5	2000.0	120.000	Vertical	19.5	30.5	57.0	
498.270000	39.8	2000.0	120.000	Vertical	19.6	17.2	57.0	
534.990000	27.5	2000.0	120.000	Vertical	20.1	29.5	57.0	
548.310000	23.4	2000.0	120.000	Vertical	21.5	33.6	57.0	
593.355000	23.2	2000.0	120.000	Vertical	21.4	33.8	57.0	
654.555000	36.2	2000.0	120.000	Vertical	21.9	20.8	57.0	
681.735000	24.0	2000.0	120.000	Vertical	22.0	33.0	57.0	
710.895000	26.1	2000.0	120.000	Vertical	22.7	30.9	57.0	
793.110000	45.5	2000.0	120.000	Vertical	23.4	11.5	57.0	
835.725000	26.6	2000.0	120.000	Vertical	23.8	30.4	57.0	

Emissions in the above table marked with an asterisk represent a measured level within the limits of measurement uncertainty. See Appendix A.

EMC – Susceptibility

5.3.2 Radiated Radio Frequency Susceptibility

Level	Guidance Document Performance Criteria	
	Actual	Required
10V/m, 80 % AM	N/A	A

Note: Not carried out due to on site restrictions. See Section 4.2.2.

Licensed Transmitters

Level	Guidance Document Performance Criteria	
	Actual	Required
10V/m @ 440, 450, 460 & 470 MHz	A	A

Compliant to performance criteria A for this test.

Cellular Telephone

Level	Guidance Document Performance Criteria	
	Actual	Required
3 V/m @ 910 MHz	A	A

Compliant to performance criteria A for this test.

Siting

The sterilizer would normally be mounted within a wall aperture, the dimensions of which are shown on the General Arrangement drawing. This type of installation separates the process equipment and services to the sterilizer (the plantroom or dirty area) from the working area on the facia side of the sterilizer. This method of installation will also minimise the noise levels and heat emissions to the working area.

With the sterilizer in its final position, the height of the sterilizer and level within the chamber should be checked. The adjustable support feet should be adjusted evenly, using an appropriately sized spanner, to raise or lower the sterilizer. The height to the lower edge of the facia panels from the floor should be set at a nominal distance of 100mm. If more than one sterilizer is being installed, or a sterilizer is installed next to a pre-existing unit, the height should be adjusted so that the facia panel work of adjacent machines are aligned.

With the height adjusted, place a small spirit level on the chamber floor and check that the chamber is level across its width and from back to front. If the chamber floor is not level in either direction, make adjustments to the support feet to achieve this condition, whilst still maintaining the nominal distance of 100mm from floor to facia panel work or alignment with the panel work of adjacent machines.

NOTE - IT IS IMPORTANT THAT THE CHAMBER FLOOR IS LEVEL SO THAT CONDENSATE FORMED DURING A PROCESS CYCLE CAN FLOW FREELY TOWARDS THE CHAMBER FLOOR DRAIN AND BE REMOVED FROM THE STERILIZER.

Services

Electrical

A disconnection device such as a mains isolator must be fitted between the sterilizer and the incoming mains supply. The device should be sited within 2 metres of the machine and unobstructed to allow for easy and quick access. The disconnection device should conform to the requirements of IEC 60947 or an equivalent standard, and sized to meet the electrical rating for the sterilizer.

The cable supplying power to the sterilizer should be adequately sized to meet the load requirement and secured with appropriate cable glands. The cable must have 5 cores (3 Phase + Neutral + Earth) and meet the requirements of BS 7919:2001 or an equivalent standard. Cable glands should meet the requirements of BS 6121-1:2005 or equivalent.

The sterilizer must be earthed to the mains supply.

WARNING – CHECK THE ELECTRICAL REQUIREMENTS GIVEN ON THE LABEL ATTACHED TO THE COVER OF THE STERILIZER CONTROL BOX ENCLOSURE. THE INCOMING ELECTRICAL SUPPLY SHOULD BE SUITABLY SIZED WITH A MAINS ISOLATOR PROVIDE TO SWITCH ALL POLES SIMULTANEOUSLY AND APPROPRIATELY FUSED TO MEET THESE REQUIREMENTS.

WARNING – BEFORE MAKING ANY ELECTRICAL CONNECTIONS ENSURE THAT THE MAIN ISOLATOR SWITCH TO WHICH THE STERILIZER IS CONNECTED IS TURNED OFF AND THE ISOLATOR FUSES ARE REMOVED. LOCK THE ISOLATOR IN THE OFF POSITION. AN AUTHORISED AND COMPETENT ENGINEER MUST MAKE THE CONNECTION.

WARNING – DO NOT TURN ON THE MAINS ISOLATOR AT THIS STAGE. MAINTAIN ISOLATOR IN LOCKED POSITION.

Steam

The steam supply to the machine is connected at the steam inlet as shown in the General Arrangement drawing at the back of this manual. The pipe supplying steam to the machine should be sized to carry the maximum steam flow as detailed in the Service Requirements section. The connection should include a shut off valve and a pipe union of appropriate size between the sterilizer connection and the shut off valve.

NOTE – THE STEAM SUPPLY SHOULD BE OF GOOD QUALITY AND COMPLY WITH THE REQUIREMENTS OF CFPP-01:PART C AND BS EN 285:2015 ANNEX B. FOR PROCESSING MEDICAL DEVICES THE STEAM SHOULD FURTHER MEET THE REQUIREMENTS OF HTM 2031 – CLEAN STEAM FOR STERILIZATION.

WARNING – THE STEAM SUPPLY SERVICE PRESSURE SHOULD NOT EXCEED 4.5 BAR. A SAFETY VALVE SET TO RELIEVE AT A PRESSURE OF 4.5 BAR MAXIMUM SHOULD BE FITTED TO THE SUPPLY. THE SAFETY VALVES FITTED TO THE STERILIZER ARE SIZED TO HANDLE THE MAXIMUM FLOW CAPACITY OF THE STERILIZER CONTROL VALVES FOR A MAXIMUM SUPPLY PRESSURE OF 4.5 BAR.

NOTE – THE STEAM SUPPLY SHOULD BE CAPABLE OF SUPPLYING STEAM AT A RATE EQUAL TO OR GREATER THAN THAT GIVEN IN THE TECHNICAL SPECIFICATIONS (AT FRONT OF MANUAL) FOR THE SIZE OF THE STERILIZER BEING CONNECTED.

CAUTION – ALL STEAM LINES SHOULD BE PROPERLY INSULATED TO PROTECT PERSONNEL AND INCREASE OPERATING EFFICIENCY.

CAUTION – DO NOT TURN THE STEAM SHUT OFF VALVE ON AT THIS STAGE.

Drain

CAUTION – THE DRAINAGE SYSTEM WITHIN THE BUILDING, RECEIVING EFFLUENT FROM THE STERILIZER, SHOULD COMPLY WITH THE REQUIREMENTS OF CFPP-01:PART C.

NOTE – THE DRAINAGE SYSTEM SHOULD BE CAPABLE OF REMOVING EFFLUENT AT A RATE GREATER THAN THAT GIVEN IN THE SERVICE REQUIREMENTS (AT FRONT OF MANUAL) FOR THE SIZE OF THE STERILIZER BEING CONNECTED. THE DRAINAGE SYSTEM WITHIN THE BUILDING SHOULD IDEALLY BE NOT LESS THAN 100mm DIAMETER.

The drainpipe should be fitted to the sterilizer as shown in the General Arrangement drawings at the front of this manual.

The outlet of this pipe should be connected to the building drainage system. This would normally be achieved using 35mm brass compression fittings and 35mm diameter copper pipe. The pipe work connecting the sterilizer drain to the building drainage system should slope in a downward direction to the building drainage system

Water

The water supply to the machine is connected at the strainer inlet that leads to the water control valves or water break tank. The water tank, if fitted to the sterilizer has a class 'A' air break and fully compliant with Water Board Regulations. If fitted without a water break tank a double check valve is fitted after the strainer to prevent back-syphoning. Refer to the Service Requirements for the size of the inlet connection for each type of sterilizer. The pipe supplying water to the machine should be sized to provide the flow and pressure requirements as listed in the Technical Specification of this manual.

NOTE – THE WATER SUPPLY SHOULD BE OF POTABLE QUALITY, AND AT A TEMPERATURE OF 15°C OR LESS. THE WATER HARDNESS SHOULD BE IN THE RANGE OF 0.7-2.0 mmol litre⁻¹. SEE CFPP-01:PART C FOR FURTHER DETAILS.

NOTE – THE WATER SUPPLY SHOULD BE CAPABLE OF SUPPLYING WATER AT A RATE EQUAL TO OR GREATER THAN THAT GIVEN IN THE SERVICE REQUIREMENTS FOR THE SIZE OF THE STERILIZER CONNECTED.

Air

Refer to the General Arrangement drawings at the front of this manual for the position of the inlet connection for each type of sterilizer. The Service Requirements section details the connection size. The Air Manifold Station includes a manual shut-off valve.

When the air supply has been connected and the shut-off valve opened, adjust the knurled knob on the inlet filter/regulator to give a pressure of 6 bar on the filter/regulator gauge.

NOTE – THE AIR SUPPLYING THE STERILIZER SHOULD BE FREE FROM LIQUID WATER, FILTERED TO REMOVE PARTICLES GREATER THAN 25µm, AND LUBRICATED WITH OIL PARTICLES GREATER THAN 2µm. BLOW OUT THE AIR LINE BEFORE MAKING THE FINAL CONNECTION.

Safety Valves

Safety valves should be piped to atmosphere to discharge in a safe manner and the outlet protected from weather conditions, i.e. the ingress of water. The minimum pipe size used should be that of the outlet size of the safety valve – see the Service Requirements section of this manual for the outlet sizes for each type of sterilizer.

The pipe diameter may have to be increased progressively along the pipe run to atmosphere, particularly if the pipe run is long. This would be required to reduce the resistance to flow and back pressure. Consult the Competent Person (pressure vessels) for advice.

CAUTION – TO REDUCE THE BACK PRESSURE ON THE SAFETY VALVE, THE DIAMETER OF THE SAFETY VALVE DISCHARGE PIPE SHOULD BE PROGRESSIVELY INCREASED IN SIZE FOR LONG PIPE RUNS. INCREASING THE BACK PRESSURE ON THE SAFETY VALVE REDUCES THE QUANTITY OF STEAM THAT IT IS ABLE TO DISCHARGE. CONSULT THE COMPETENT PERSON (PRESSURE VESSELS) FOR ADVICE.

WARNING - THE OPERATING PRESSURE OF A SAFETY VALVE IS INCLUDED ON THE NAMEPLATE AFFIXED TO THE SAFETY VALVE. THE SAFETY VALVE IS SEALED BY THE SAFETY VALVE MANUFACTURER AFTER IT HAS BEEN SET AND SHOULD NOT BE ALTERED. IF THE SAFETY VALVE DOES NOT FUNCTION CORRECTLY, IT SHOULD BE CHANGED FOR A NEW REPLACEMENT. REPAIRS TO A SAFETY VALVE SHOULD ONLY BE PERFORMED BY THE SAFETY VALVE MANUFACTURER.

WARNING - THE SAFETY VALVE VENT IS FITTED WITH A 6MM DRAIN TO PREVENT ANY BUILD-UP OF WATER ON THE OUTLET SIDE OF THE VALVE. WHEN PIPING THE VENT TO A SAFE DISCHARGE POINT, IT MAY BE NECESSARY (ON LONG RUNS AND HORIZONTAL PIPES) TO FIT FURTHER DRAINAGE POINTS TO PREVENT ANY BUILD-UP OF WATER.

NOTE – CORRECT OPERATION OF THE SAFETY VALVES SHOULD BE CHECKED AS PART OF THE INSTALLATION CHECKS. THE CHECKS SHOULD BE UNDERTAKEN WHEN THE STERILIZER IS IN AN OPERATIONAL CONDITION – SEE TEST LISTED IN INSTALLATION CHECKS.

Safety Valve Testing

The operation of the sterilizer safety valve should be checked when the sterilizer is first placed into a working condition but only after all the installation checks have been made.

With the sterilizer not in cycle but with the jacket temperature being controlled, press the manual override button on solenoid valve SV09. This will open the steam to jacket valve. When the maximum flow condition is reached check that the pressure within the jacket, with the safety valve relieving, does not exceed 2.88 bar (10% above the design pressure for the jacket).

Service Requirements – Single/Double Ended

Model Number		P106	P108	P106D	P108D
Chamber Size	CU.FT	6	8	6	8
	LITRES	160	230	160	230
	WxHxL	350 x 670 x 680	350 x 670 x 980	350 x 670 x 680	350 x 670 x 980
USABLE CHAMBER SPACE	WxHxL	320 x 630 x 650	320 x 630 x 950	320 x 630 x 650	320 x 630 x 950
LOADING CAPACITY	STU	2	3	2	3
CONSTRAINS	Design Pressure 2.6 bar Allowable Working Pressure 2.48 bar Allowable Working Temperature 140°C				
Compressed Air	All machines - Pressure 5.5 – 6.0 Bar (6 BAR MAXIMUM) Without intergral air compressor				
CONNECTION	BSPT	¼" OR 6mm PUSH FIT			
At 6bar - Max. FLOW	L/MIN	6	6	6	6
At 6bar - Max. FLOW (BALLASTING)	L/MIN	25	28	25	28
At 6bar - CONSUMPTION	L/HR	24	26	24	26
At 6bar - Max. FLOW (BALLASTING)	L/HR	240	260	240	260
QUALITY	AIR FOR CONTROLS - FREE OF LIQUID WATER FILTERED TO 25µm LUBRICATED OIL PARTICLES < 2µm (BALLAST AIR SHOULD BE FILTERED TO REMOVE OIL-MIST AND MICRO-ORGANISMS. MAXIMUM LIMIT OF 0.5mg OF OIL PER CUBIC METRE OF FREE AIR [MEASURED AT 1013mbar AND 20°C; SEE ISO 554], BE FILTERED TO AN EFFICIENCY OF AT LEAST 95% WHEN TESTED IN ACCORDANCE WITH BS3928 AND BE FREE OF BACTERIA)				
Air	All machines - With intergral air compressor				
Connection	BSPT	1/4" OR 8mm PUSH FIT			
At 6bar - Max. FLOW	L/MIN	N/A	N/A	N/A	N/A
At 6bar - Max. FLOW (BALLASTING)	L/MIN	N/A	N/A	N/A	N/A
At 6bar - CONSUMPTION	L/HR	N/A	N/A	N/A	N/A
At 6bar - Max. FLOW (BALLASTING)	L/HR	N/A	N/A	N/A	N/A
Potable Water	All machines - Pressure 1.5 – 5 Bar Potable Quality Temperature < 15°C Hardness Range 0.7-2.0 mmol ⁻¹				
CONNECTION	BSPT	¾" OR 22mm Copper Pipe			
MAXIMUM FLOW	L/MIN	35	35	35	35
CONSUMPTION	L/Cycle	280	300	280	300
Treated Water	To supply integral generator when fitted - Pressure 1.5 – 5 Bar Maximum contaminants in feed water to generator to EN285				
CONNECTION	BSPT	3/8" OR 8mm PTFE			
MAXIMUM FLOW	L/MIN	3	3	3	3
CONSUMPTION	L/Cycle	15	20	15	20

Steam Supply		Plant steam to supply machine with no integral steam generator			
STEAM PRESSURE	BARG	3.5 – 4.5 WARNING – SUPPLY TO STERILIZER TO BE FITTED WITH SAFETY VALVE SET AT 4.5 BAR MAX.			
CONNECTION	BSPT	3/8" OR 8mm PTFE			
MAXIMUM FLOW	KG/HR	100	115	100	115
CONSUMPTION	KG/Cycle	16	18	16	18
QUALITY		(NON CONDENSABLE GASES < 3.5% SUPERHEAT < 25°C DRYNESS >0.9/0.95 SEE EN285 ANNEX B)			
Electricity Supply		400 VOLTS 3N 50HZ See layout drawing of machine for site electrical isolation			
POWER	kW	2.25	2.25	2.25	2.25
POWER WITH BOILER	KW	20.25	20.25	20.25	20.25
AMPS/PHASE	AMPS	3.9	3.9	3.9	3.9
AMPS/PHASE WITH BOILER	AMPS	30	30	30	30
Drain Connection	BSPT	1"			
MAX. FLOW	LTS/MIN	33	36	33	36
MAX. TEMPERATURE	°C	80	80	80	80
Safety Valve		Safety valve vents should be piped to a safe discharge point. Ideally to outside of building and weather protected.			
STERILIZER	VENT mm	22	22	22	22
GENERATOR	VENT mm	22	22	22	22
Sound Power	dBA	68			
Heat Emissions - Plantroom	kW	3.5	4.1	4.3	4.6
FACIA SIDE	kW	0.9	0.9	0.9	0.9
INTEGRAL GENERATOR	kW	1	1	1	1

Installation Checks

1. Service Checks

- a. Turn the water supply on and check that the water flows freely into the break tank (if fitted). Check for any water leaks. Check that the water supply pressure lies within the range given in the technical specification sheet – see front of manual.
- b. Turn on the electrical supply to the sterilizer. Turn the sterilizer isolator switch to the on position. The operator display screen should illuminate, and display either the open door or closed door menu screen.
- c. Turn on the air supply and check that the main pressure regulator is adjusted to give a supply pressure that lies within the range given in the technical specification sheet – see front of manual. Check for any leaks
- d. Crack open the main steam valve and allow the steam pressure to build up slowly. Check for any leaks. If leaks are evident, turn off the steam and allow the pipe work to cool before attempting to repair the leak.

WARNING – DO NOT ATTEMPT TO WORK ON THE STEAM PIPEWORK OR PRESSURE VESSEL WITHOUT FIRST TURNING THE STEAM OFF AT THE ISOLATING VALVE. ALWAYS WAIT FOR THE PRESSURE TO DECAY TO ATMOSPHERIC PRESSURE BEFORE ATTEMPTING ANY WORK. ALWAYS WEAR HEAT PROTECTIVE GLOVES AND CLOTHING WHEN WORKING WITH PARTS LIKELY TO BE HOT

2. Door Checks

- a. Using the door *open* and *close* button on the touchscreen, open and close the door. Check that the door travels freely between the open and closed positions. Check that there is approximately a 3mm clearance between the face of the door and the door seal.
- b. On a double ended sterilizer, Door 2 must be sealed before any other operations are available. If an integral steam generator is fitted, the generator must be turned on and the steam pressure raised before the door can be sealed.
- c. When the door is closing, remove finger from close door button. The door travel should be reversed, the door moving to the open position.
- d. On single and double ended sterilizers, entering the Maintenance Menu – Door Operations, will permit the sealing, unsealing and operation of the doors.
- e. When the door is moving to the closed position, operate the emergency stop button. The door should stop moving. Check the event sequence for the operation and resetting of the emergency stop button as detailed in the User Manual provided with the sterilizer.

3. Pump Checks

- a. Select the *digital outputs* option within the maintenance menu. Select the output for the vacuum pump and allow the pump to run for two seconds. The direction of rotation of the vacuum pump should be noted and checked against the rotation marked on the pump. If the pump rotates in the wrong direction two phases within the sterilizer isolator enclosure should be interchanged.

WARNING – BEFORE INTERCHANGING ELECTRICAL CONNECTIONS ENSURE THAT THE MAIN ISOLATOR SWITCH TURNED OFF AND THE ISOLATOR FUSES ARE REMOVED. LOCK THE ISOLATOR IN THE OFF POSITION. AN AUTHORISED, COMPETENT ENGINEER MUST MAKE THE CONNECTION.

Recheck the direction of the vacuum pump.

- b. With the vacuum pump running, check that a vacuum is being pulled. This can be checked by feeling the end of the 6mm anti-cavitation pipe situated within the water break tank, or if without tank track the nylon pipe line from the end of the vacuum pump and feel the end of this pipe. If a needle valve is fitted in this line it should be adjusted to give a slight air intake to the pump.

CAUTION – DO NOT RUN THE VACUUM PUMP FOR MORE THAN 10 SECONDS IF NO VACUUM IS EVIDENT AT THE INLET OF THE ANTI-CAVITATION LINE.

- c. If no vacuum is generated, the vacuum pump may need to be primed with water. Remove the vacuum pipe connected to the inlet of the heat exchanger, then carefully pour about 4 litres of water into the heat exchanger – this water will flow into the vacuum pump to establish the primed condition.

Re-run the pump to establish that a vacuum is being generated.

- d. Next select the output for the water circulating pump (if fitted). Water should be drawn from the break tank and pumped through the heat exchanger before being return to the break tank. Remove the lid of the water break tank to identify the return pipe from the heat exchanger. Feel the outlet of this pipe to establish whether water is flowing.

CAUTION – DO NOT RUN THE CIRCULATING PUMP FOR MORE THAN 10 SECONDS IF NO WATER FLOW IS EVIDENT AT THE OUTLET OF THE RETURN PIPE FROM THE HEAT EXCHANGER.

- e. If no water is flowing, the circulating pump may need to be primed with water. On the outlet side of the pump, loosen the first pipe compression joint. When water flows from this joint, retighten the joint and try the circulating pump again.
- f. If the sterilizer is supplied without a water break tank select the output for high water flow. Check that the indication light illuminates on the corresponding valve (SV102). The same check can be done for low water flow (SV103).

4. Maintenance Menu Checks

- a. Enter the maintenance menu and select the Door Operations option. Seal and unseal the door to establish that the door mechanism is working correctly. See the Door Safety section of the maintenance manual for the checks to be undertaken.
- b. Check the operation and setting of the service pressure for air, steam and water.
- c. Select the Digital Inputs option within the Maintenance Menu. The screen will display the on/off status of the inputs from pressure switches, limit switches and motor overloads.

Slowly turn off the steam supply to the sterilizer, and note the pressure at which the input turns off. The pressure switch is normally set to between 2.2 to 2.5 bar. If adjustment of pressure switch PS05 is necessary, refer to the components section of the maintenance manual.

Slowly turn off the air supply to the sterilizer, and note the pressure at which the input turns off. The pressure switch is normally set between 5.5 to 6.0 bar. If adjustment of pressure switch PS03 is necessary, refer to the components section of the maintenance manual.

- d. Check the calibration of the temperature and pressure channels as described in the System Calibration section of this manual.
- e. Check the operation of the safety valve as described in the Safety Valve section of this manual.

5. Electrical Checks

- a. Carry out tests to check the insulation resistance, earth bonding and continuity of the sterilizer. The procedures for carrying out these checks are as described in the Electrical Checks section of this manual.

Insulation Resistance Test

WARNING – THE INSULATION RESISTANCE TEST MUST BE PERFORMED BY A COMPETENT ELECTRICIAN OR AN APPROPRIATELY TRAINED MAINTENANCE PERSON.

1. Test equipment - insulation resistance tester (megohmmeter) 500V DC
2. Before carrying out the test check that the tester is functioning correctly.
Short the test leads of the tester together, press the test button/switch on tester to commence test. The test reading should be zero ohms.
Open circuit test leads of the tester, press test button/ switch on tester to commence test. The test reading should be infinity ohms.
If any of the above tests fail, do not continue with test. Replace or have test meter repaired.
3. Turn the electrical power supply to sterilizer off at the main isolator switch (normally on wall near sterilizer). Disconnect the neutral link in the main isolator switch, to isolate the neutral from the sterilizer. **Lock the isolator in off position, to prevent unauthorised return to on position.**
4. Also before carrying out the tests, ensure that the sterilizer has all its fuses fitted and are not blown. Also check that the manual motor starters are switched to the on position.
5. Check isolator to contactors, fuses, and transformers.
At the isolator on the sterilizer, temporarily short out the incoming terminals, (on the isolator, 3 phase and neutral connection).
Turn the isolator that is fitted on the sterilizer to the on position.
Connect the insulation resistance tester between the shorted terminals on the isolator and the main earth terminal (next to the isolator).
Press test button/switch on tester to commence test. Test for a period of at least 10sec.
Pass value equals 2M ohms or greater. Record value on commissioning checklist.
6. If emergency contactor MCR is fitted operate contactor by pressing the moving contacts in with an insulated screwdriver, hold in while test as in 2.5 is repeated.
7. Remove all temporary shorts, and release the moving contacts of MCR if fitted.
8. Check vacuum pump motor.
Remove the terminal box cover of motor, temporarily short out the connecting terminals, (do not remove the machine wiring to the terminals).
Connect the insulation resistance tester between the shorted terminals and the earth terminal (in motor terminal box).
Press test button/switch on tester to commence test. Test for a period of at least 10sec.
Pass value equals 2M ohms or greater. Record value on commissioning checklist.
Remove the temporary short, and replace the terminal box cover.
9. Check water boost pump motor if fitted
Remove terminal box cover of motor, temporarily short out the connecting terminals, (Do not remove the machine wiring to the terminals).
Connect the insulation resistance tester between the shorted terminals and the earth terminal (in motor terminal box).
Press test button/switch on tester to commence test. Test for a period of at least 10secs
Pass value equals 2M ohms or greater. Record value on commissioning checklist.
Remove the temporary short, and replace the terminal box cover.
10. Check water circulation pump (if fitted)
Remove terminal box cover of motor, temporarily short out the connecting terminals, (Do not remove the machine wiring to the terminals).
Connect the insulation resistance tester between the shorted terminals and the earth terminal (in motor terminal box).
Press test button/switch on tester to commence test. Test for a period of at least 10sec.
Pass value equals 2M ohms or greater. Record value on commissioning checklist.
Remove the temporary short, and replace the terminal box cover.
11. Ensure all temporary shorts have been removed.
The moving contacts of the emergency contactor MCR are released. Turn the isolator that is fitted on the sterilizer to the off position. Re-connect the neutral link in the main switch.

Bonding and Earth Continuity

1. Test equipment required - Earth bond tester, test current 25amps.
2. Before carrying out the test check the tester is functioning correctly.
Short the test leads of the tester together. Press test button/switch on tester to commence test.
Test reading should be the resistance of the test leads (< .01 ohms). Record value on commissioning checklist.
Open circuit test the leads of the tester. Press test button/switch on tester. Reading should be infinity ohms.
If any of the above tests fail, do not continue with test. Replace or have test meter repaired.
3. Turn the electrical power supply to sterilizer off at the main isolator switch (normally on wall near sterilizer). Lock in OFF position, to prevent unauthorized return to on position.
4. Also before carrying out the tests, ensure the sterilizer has all fuses fitted and are not blown, also that the manual motor starters are switched to the ON position.
5. Check main earth to front panels.
Connect the earth bond tester between main earth terminal (in the isolator box on the sterilizer), and in turn to each individual panel that make up the front paneling of the sterilizer
Press test button/switch on tester to commence test. Test for a period of at least 10sec.
Pass value equals 0.1ohms or less. Record the value on commissioning checklist.
6. Check main earth to door panels.
Connect the earth bond tester between main earth terminal (in the isolator box on the sterilizer), and in turn to the door panel of the sterilizer
Press test button/switch on tester to commence test. Test for a period of at least 10secs
Pass test value equals 0.1 ohms or less. Record the values on commissioning checklist.
7. Check main earth to chamber insulation panels.
Connect the earth bond tester between main earth terminal (in the isolator box on the sterilizer), and in turn to each individual panel that make up the chamber insulation panel
Press test button/switch on tester to commence test. Test for a period of at least 10sec.
Pass test value equals 0.1 ohms or less. Record the values on commissioning checklist.
8. Check main earth to motors.
Connect the earth bond tester between main earth terminal (in isolator box on the sterilizer), and in turn to each motor, vacuum pump, water pump, water circulation pump, door motor, using the earth terminal of the motor, if not available use, one of the screws used for fixing the lid to the terminal box of the motor.
Press test button/switch on tester to commence test. Test for a period of at least 10sec.
Pass test value equals 0.1 ohms or less. Record the values on commissioning checklist.
9. Check main earth to the ACU enclosure.
Connect the earth bond tester between main earth terminal (in the isolator box on the sterilizer), and one of the screws used for fixing the door to the ACU enclosure. Press test button/switch on tester to commence test. Test for a period of at least 10sec.
Pass test value equals 0.1 ohms or less. Record the values on commissioning checklist.
10. Check main earth to VDU and switches enclosure
Connect the earth bond tester between main earth terminal (isolator box sterilizer), and rear of the fascia enclosures.
Press test button/switch on tester to commence test. Test for a period of at least 10sec.
Pass test value equals 0.1 ohms or less. Record the values on commissioning checklist.
11. Check the main earth to the main isolator switch – normally on wall near the sterilizer.
Connect the earth bond tester between main earth terminal (in the isolator box on the sterilizer), and the rear of the fascia enclosure.
Press test button/switch on tester to commence test. Test for a period of at least 10sec. Pass test value equals 0.1 ohms or less. Record the values on commissioning checklist.

INSTALLATION CHECKS

WARNING – WHEN THE ABOVE TESTS HAVE BEEN SATISFACTORILY COMPLETED, ENSURE ALL TEMPORARY SHORTS ARE REMOVED, ANY DISCONNECTED WIRES AND LINKS ARE RECONNECTED, AND ALL LIDS HAVE BEEN REPLACED ON TERMINAL BOXES AND ENCLOSURES. THE MAIN SWITCH CAN NOW BE UNLOCKED, AND SWITCHED ON TO RESTORE ELECTRICAL POWER TO THE STERILIZER.

INSTALLATION CHECKS

Installation Checklist

GENERAL	CHECKED		
No defects are apparent from a visual inspection of the equipment.			
Supports & fixings are secure and do not put strain on service connections			
Machine is at the correct height, and level so that all condensate fall to drain			
DOOR			
Door/s central to chamber aperture.			
Door limit switch and air valve adjusted and in correct positions operating when door is closed.			
Door/s seal, unseal, open and close correctly			
Door retaining bar screws have been correctly torque on re-assembly. (as necessary)			
SERVICES	Steam	Water	Air
Services are installed correctly and do not leak			
Services are adequate to meet the demands of the equipment			
DRAINS, CONDENSATE & VENTS			
Condensate lines operate effectively when all plant is connected			
Drains remove effluent effectively when all plant is connected			
Vents for the safety valves are of adequate size and vented to a safe location			
The water conservation system (if fitted) operates correctly			
Thermal insulation is in good condition and securely attached			
ELECTRICAL			
Electrical supply is correctly connected to equipment.			
Insulation resistance test			
Phase sequence for three phase installations			
Polarity check			
Bonding and earth continuity			
Emergency Stop			
FUNCTIONAL			
The selection of automatic or manual control is by key, code or tool			
When the control is in manual mode the automatic control is inactivated			
When the control is in automatic mode the manual control is inactivated			
Door seals, unseals, opens and closes. Door components visually checked			
The cycle cannot be started until all doors are closed and sealed			
Manual control-Steam cannot be admitted to the chamber until door is sealed			
Throughout the cycle, indicated and recorded Steam, Water and Air pressures are within the limits for safe and efficient operation of the machine	Steam	Water	Air
Throughout the cycle there are no leaks of steam, water air or effluent			
There is no evidence of interference to equipment connected to the same services			
There is no evidence of electromagnetic interference to or from other equipment			
Operation and reading of all instruments appear satisfactory			
Temperature of surfaces routinely handled by the operator does not exceed 50'c			
The effluent temperature does not exceed 80'c			
AT THE END OF CYCLE			
Door cannot be opened until the chamber pressure is within 0.2 Bar of atmosphere (Chamber pressure switch setting – PS4 - Set at 0.2 Bar)			
Door travel mechanism cannot be energised until the seal between the door and chamber has been broken and the chamber is effectively vented to atmosphere			
FAULT CONDITIONS			
Operation of emergency stop			
Power failure			
Steam pressure too low (Steam pressure switch setting - PS2 - Set at 2.0 Bar)			
Compressed air pressure too low (Air pressure switch setting - PS1 - Set at 4.0 Bar)			
Door 1 seal pressure switches set (PS9 +0.8bar seal door /PS8 -0.2 unseal door)			
Door 2 seal pressure switches set (PS29 +0.8bar seal door /PS28 -0.2 unseal door)			
Water capacity too low – with water break tank only OR			
Water pressure to low (water pressure <1.5bar) – without water break tank.			
Check operation of safety valve. Valve opening pressure			bar
LOADING EQUIPMENT			
Loading equipment aligns with the chamber rails, carriage can freely move in and out			
Trolley securely locks onto the sterilizer when transferring carriage into chamber			
Carriage is securely locked onto trolley for safe maneuvering			

Validation

The sterilizer should now be tested in accordance with the tests detailed in the relevant sections of CFPP 01-01 or otherwise to customer protocols.

Documented evidence should be obtained to show that the sterilizer meets the requirements of these tests. Details of the required documentation are provided in CFPP 01-01 series of publications. An Authorising Engineer, as defined in CFPP 01-01 should audit all test results.

CAUTION – THE VALIDATION AND COMMISSIONING TESTS SHOULD BE PERFORMED BY A SUITABLY QUALIFIED PERSON AS DEFINED IN CFPP 01-01.

CAUTION – THE VALIDATION AND COMMISSIONING TESTS SHOULD BE AUDITED BY AN AUTHORISING ENGINEER AS DEFINED IN CFPP 01-01.

Loading Shelves

If loading shelves have been supplied with the sterilizer, they may be extended and retracted by gripping the handle and pushing or pulling as appropriate.

CAUTION- GLOVES SHOULD BE WORN WHEN LOADING OR UNLOADING THE SHELVES.

CAUTION - WHEN RETRACTING SHELVES ENSURE THAT THEY HAVE REACHED THE STOP POINT AT THE REAR OF THE CHAMBER SO THAT THEY DO NOT IMPEDE THE MOTION OF THE STERILIZER DOOR AS IT CLOSES.

CAUTION - SPREAD LOADS EVENLY ACROSS THE LENGTH AND WIDTH OF THE LOADING SHELF. OVERLOADING OR IMPROPER LOADING MAY CAUSE DAMAGE OR DEFORMATION TO THE SHELF AND HARM TO THE USER.



Shelves in closed position



Shelves in open position

Loading Trolley Adjustment

If loading trolleys have been supplied with the sterilizer, these can now be adjusted so that the height of the trolley rails are the same as those within the chamber.

Adjust the height of the trolley by means of the threaded supports that attach the wheels to the trolley. The adjustment screw locking nut should be released and the adjustment screw turned to raise or lower the trolley. The trolley should be adjusted so that the rails on the trolley are the same height as those within the chamber, whilst still maintaining the trolley rails level.

CAUTION – FOR MACHINES WITH A GREATER DISTANCE OF 100mm BETWEEN THE FLOOR AND BOTTOM PANELS, AFTER ADJUSTING THE TROLLEY HEIGHT CHECK THAT THERE IS AT LEAST 25mm OF THREAD ENGAGEMENT OF THE TROLLEY ADJUSTMENT SCREW WITHIN THE FRAME OF THE TROLLEY. DO NOT USE IF LESS THAN 25mm – LONGER ADJUSTMENT SCREWS WILL BE REQUIRED TO ENSURE STABILITY AND USER SAFETY.

CAUTION – AFTER ADJUSTING THE TROLLEY TO THE CORRECT HEIGHT, ALWAYS ENSURE THAT THE ADJUSTMENT SCREW NUT ARE FULLY TIGHTENED.

When the trolley rails have been aligned to the chamber rails, remove the trolley clear of the sterilizer and carefully place an empty loading carriage onto the trolley.

CAUTION – THE WEIGHT OF AN EMPTY LOADING CARRIAGE VARIES BETWEEN 25 TO 45KG DEPENDING ON SIZE OF THE STERILIZER. LIFTING AND POSITIONING THE EMPTY LOADING CARRIAGE SAFELY ONTO THE TROLLEY WILL REQUIRE TWO PERSONS.

With the loading carriage positioned on the trolley rails, move the carriage towards the steering end of the trolley until the carriage wheel strikes the stop bar mounted on the trolley rail. In this position, operate the trolley black handled locking device (to the lock position) and check that the locking bar on this device prevents the carriage from moving forward – see figure 2.

Move the trolley and carriage to the sterilizer loading position with the trolley rails touching the chamber rails. Move the trolley locking handle to the unlock position. The carriage locking bar should now engage the chamber locking plate to prevent the trolley moving when then carriage is pushed into the chamber - see figure 2. This operation lowers the carriage locking bar to release the carriage.

Check that the loading trolley wheel locks operate correctly. Pushing the wheel lock lever downwards will lock the wheel, and raising the lever will unlock the wheel.

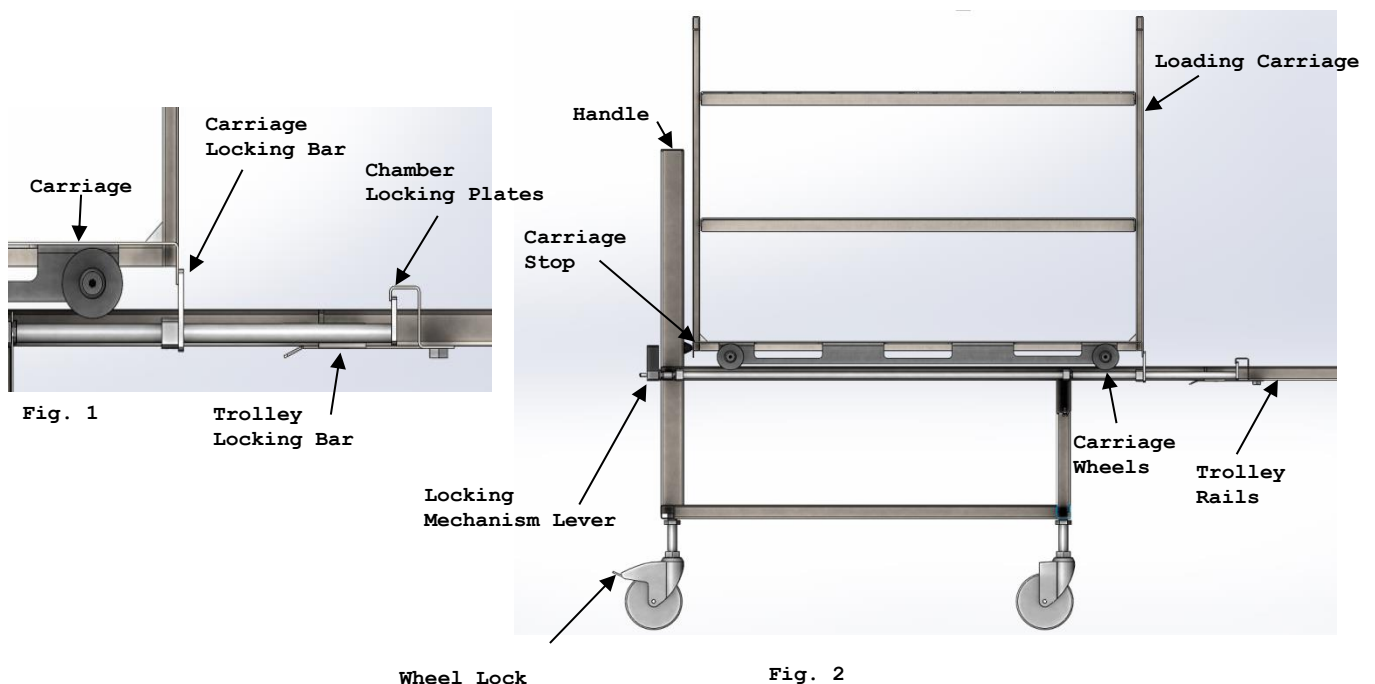

Maintenance Programme

Safety Procedures

CAUTION – BEFORE CARRYING OUT ANY OF THE INSTRUCTIONS BELOW, READ THE GENERAL SAFETY INSTRUCTIONS AT THE FRONT OF THIS MANUAL.

CAUTION – ALL STERILIZERS KEYS SHOULD BE HELD IN SAFE AND SECURED STORAGE. THE ISSUING OF KEYS SHOULD BE AUTHORISED BY THE PERSON/S WHO IS/ARE RESPONSIBLE FOR THE SAFE STORAGE OF THE STERILIZER KEYS.

CAUTION – AFTER USE, NO KEY SHOULD BE LEFT IN THE KEY SWITCH. THE KEY SHOULD BE RETURNED TO THE PERSON/S WHO IS/ARE RESPONSIBLE FOR THE SAFE STORAGE OF THE STERILIZER KEYS.

WARNING – DO NOT PUT THE STERILIZER BACK INTO USE UNLESS ALL THE PERIODIC TESTS PASS SATISFACTORILY. REPAIR OR CORRECT ANY NON- CONFORMITY BEFORE PUTTING THE STERILIZER BACK INTO USE.

WARNING – IF ANY RESULTS FAIL TO MEET THE REQUIREMENTS OF THE APPROPRIATE TEST, DO NOT USE THE STERILIZER. REPORT THE FAILURE TO THE PERSON RESPONSIBLE FOR THE STERILIZER. THE STERILIZER SHOULD ONLY BE USED AFTER THE CAUSE OF THE FAILURE HAS BEEN ESTABLISHED AND CORRECTIVE ACTION HAS BEEN TAKEN.

Daily Maintenance

These tasks can be carried out by the user/operator.

CAUTION – WHEN CLEANING OR INSPECTING THE DOOR SEAL, ALWAYS WEAR HEAT PROTECTIVE GLOVES. DOOR AND CHAMBER COMPONENTS ARE LIKELY TO BE VERY HOT AND TO CAUSE BURNS.

1. Clean the surface of the door seal with a damp cloth, wetted with water, to remove any deposits.
2. Visually inspect the condition of the door seal checking for any cuts or damage that might affect its ability to seal when the door is in a locked state. If any doubt exists as to the condition of the door seal, report this to the person responsible for the sterilizer.
3. The stainless steel fascia panel can be cleaned with a damp cloth, wetted with water or disinfectant. A liquid stainless steel polish can be used but check that its use does not present any microbial problems. Clean the Touchscreen and printer cover with a damp cloth, wetted with water. Do not use any solvent cleaners on these surfaces

CAUTION – WHEN REMOVING THE CHAMBER FILTER AND/OR CLEANING THE CHAMBER, ALWAYS WEAR HEAT PROTECTIVE GLOVES AND CLOTHING. CHAMBER PARTS ARE LIKELY TO BE VERY HOT AND TO CAUSE BURNS.

WARNING– DO NOT ENTER THE STERILIZER CHAMBER WITHOUT FIRST OBTAINING THE KEY FOR THE AUTO/MANUAL DOOR SWITCH, TURNING THE SWITCH TO THE MANUAL POSITION AND REMOVING THE KEY. KEEP IT ON YOUR PERSON UNTIL IT IS SAFE TO RETURN THE SWITCH TO THE AUTO POSITION AND FOR NORMAL OPERATION OF THE STERILIZER TO RESUME.

4. Remove the drain filter from inside the chamber, clean and replace.
5. Remove all foreign material from inside the chamber.
6. Check the display to establish that all services are turned on and that the correct readings are indicated.
7. The sterilizer should be tested daily to check that cycles continue to perform within specification. Refer to NHS Estates publication – Health Technical Memorandum 2010 Part 3 Section 5, for the test/s to be performed on a daily basis. It is advisable to run a warm-up cycle before starting the daily test/s.
8. Check the logbook and production records. Complete as required.
9. Check that the printer is loaded with sufficient paper for a day's operation.
10. Check that the recorder, if fitted, is loaded with sufficient paper for a day's operation.

Weekly Maintenance

These tasks should be carried out by the Maintenance/Test Person.

1. Check that the daily tasks have been carried out and that the daily tests have passed satisfactorily and the results entered into the sterilizer logbook.
2. Check for the correct operation of door components and safety devices:
 - a) Door alignment and door/seal clearance.
 - b) Door sealing and unsealing system.
 - c) Operation of door limit switches.
 - d) Door safety interlock systemsSee Door Maintenance section for correct operation of door sealing and safety systems.
3. Check the condition of the display, i.e. brightness and clarity.
4. Check pipework for signs of any leaks and repair as required.

CAUTION – WHERE LOCAL COMPRESSORS ARE SUPPLIED ENSURE THAT THE VESSELS ARE BLOW DOWN TO REMOVE ANY WATER THAT MAY HAVE ACCUMULATED IN THE VESSEL. IF THE COMPRESSOR IS OIL LUBRICATED, CHECK THAT THE OIL IS AT THE RECOMMENDED LEVEL. REFER TO THE COMPRESSOR MANUFACTURERS HANDBOOK (SUPPLIED WITH THE COMPRESSOR) TO UNDERTAKE THESE AND ANY OTHER RECOMMENDED MAINTENANCE TASKS. FAILURE TO COMPLETE THE CHECKS MAY INVALIDATE THE WARRANTY.

5. The easing levers on safety valves should be operated to check that the safety valves are free and pass steam.
6. Check the switching points for the services pressure switches. The switching points should be the same as those set during the installation tests – see installation checks in Installation Section of this manual.
7. Check condition of gauges and determine they are working correctly. These can be checked during the running of the Automatic control test.
8. Carry out the weekly periodic tests as detailed in HTM 2010:Part 3

Quarterly Maintenance

These tasks should be carried out by the Maintenance/Test Person.

WARNING – BEFORE CARRYING OUT ANY MAINTENANCE WORK ON THE PIPE WORK OR ITS COMPONENTS, ENSURE THAT THE SERVICES TO THE MACHINE AND THE MAIN ISOLATOR SWITCH ARE TURNED OFF. LOCK THE ISOLATOR IN THE OFF POSITION.

1. Check that the daily and weekly checks and tests have been carried out, all tests have passed satisfactorily and the results entered into the sterilizer logbook.
2. Check condition of pneumatic valves. Inspect the seat & seal in each valve and renew parts as necessary.
3. Check the condition of all strainer meshes. Clean and replace as necessary:
 - a. Water strainer (see GA Installation Section).
 - b. Filter in filter regulator (see GA in Installation Section).
4. Check the condition of all steam traps. Clean and replace elements as necessary.
5. Check condition of air replacement filters (see pipe work drawing).
6. Check the condition of the door supports and the bearings within the support rollers.
7. Check the condition of the water inlet ball valve.
8. Check the condition of 'O' ring and tri-clamp joints for leaks. Replace seals as necessary.
9. Check the condition of all contactors.
10. Check the condition of all shunt trips.
11. Carry out the quarterly periodic tests as detailed in HTM 2010: Part 3.
These tests will check the performance of the sterilizer and should reveal any defects. For Control System Calibration see Installation Manual.

Yearly Maintenance

These tasks should be carried out by the Maintenance/Test Person.

1. Check that the daily, weekly and quarterly checks have been carried out and that all tests have passed satisfactorily and the results entered into the sterilizer logbook.
2. **WARNING– THIS CHECK MUST BE PERFORMED BY A COMPETENT ELECTRICIAN OR AN APPROPRIATELY TRAINED MAINTENANCE PERSON.**
Check condition of the fuses and connections on the electrical mains, the connections within the sterilizer isolator and the mains connections within the autoclave interface unit. Inspect and tighten as necessary.
3. Replace 'O' ring and seals in all pipe work unions.
4. Check the condition of all non-return valves. Replace if the sealing surfaces are worn or damaged.
5. Check that the safety valves fitted to the sterilizer relief at the required pressure.
6. Check the calibration of all the temperature and pressure sensors fitted to the sterilizer. See topic – calibration of temperature and pressure sensors in this section of the manual.
7. Check the condition of all door elements – cylinders, guide rollers, support brackets, and wear surfaces. Check that the M20 screws that secure the door retaining bars to the sterilizer vessel are tightened to the recommended torque – see door section DG
8. Check the condition of all hoses, plastic pipes and any perishable components for any sign of degradation. Replace parts if signs of wear or degradation found.
9. Carry out the yearly periodic tests as detailed in HTM 2010: Part 3. These tests will check the performance of the sterilizer and should reveal any defects. For Control System Calibration see Installation Manual.

Replacement Parts Checklist

ALL QUARTERLY & ANNUAL SERVICES

Description	Part No.	SIZE	Complete
Door Seal	H23270/ H24398*	n/a	
Sterile Air Filter	060101	½"	

ANNUAL SERVICE

Valve Seals – replace annually		Part No.	SIZE	Complete
Jacket Valve	V22	DS586	DN15	
Steam Inlet Valve	V29	DS586	DN15	
Vacuum Valve	V13	DS589	DN32	
Drain By-pass Valve	V20	DS767	DN10	
Door Seal and Unseal Valves	V61/62	TBC	DN15	
Vent Valve	V03	DS586	DN15	
Air Detector Valve	V17	DS767	DN10	

Maintenance Schedule – Daily and Weekly

MAINTENANCE SCHEDULES – DAILY AND WEEKLY									
DEPARTMENT:			SERIAL No. DH				DATE:		
MAINTENANCE TASK – SUMMARY									
	DAILY							WEEKLY	
	S	M	T	W	T	F	S		
Clean door seal									
Examine the door seal and replace if worn or damaged									
Clean panelwork									
Clean chamber drain filter									
Check that all services are turned on									
Check printer paper									
Check recorder paper and pens (if fitted)									
Bowie-Dick Test (Porous Load sterilizers)									
Correct readings indicated on VDU									
Check that the daily tasks have been completed satisfactorily									
Examine the door closure mechanism for wear and defects.									
Check door alignment and door/seal clearance									
Check that door sealing system is working satisfactorily									
Check operation, setting of door limit switches for safe operation									
Check door safety interlocks									
Check the switching points for the door release pressure switch									
Check door support and roller mechanism									
Check pipe work for signs of any leaks									
Check condition of safety valves. Operate easing levers									
Check gauges and their calibration. Recalibrate as required									
Check water system and heat exchanger are working correctly									
Local compressors – blow down tank. If appropriate check oil.									
Replace air filters as required									
Sterilizer has been cleaned and all waste removed.									
Carry out weekly periodic tests to HTM2010 : Part 3									
Enter results and comments in Sterilizer Log Book									
Comments									
Notify the user of any defects or safety hazard. Complete the service record. Hand over to user if tests and checks are satisfactory									

MAINTENANCE ACTIVITIES

Maintenance Schedule – Quarterly and Yearly

MAINTENANCE SCHEDULES - QUARTERLY AND ANNUAL			
HOSPITAL			
DEPARTMENT			
Date of Service			
STERILIZER	Serial Number : DH	Plant Ref No:	Cycle No:
GENERAL			
Sign into department.			
Check log book for any faults or notes, consult user/operator			
Visually check for physical damage.			
DOOR CHECKS		Quarterly	Annual
Replace door seal			
Check door is central to chamber			
Check limit switch & air roller valve position for safe operation			
Check door cylinder travels required stroke. Adjust cushioning if needed.			
Check speed of door travel is satisfactory. Adjust pressure if required.			
Check air restrictors for speed control. Clean if necessary.			
PIPEWORK CHECKS		Quarterly	Annual
Check pipework and tighten as necessary.			
Check air lines for leaks. Check air filter. Replace push in fittings as required			
Check condition of services. Check service pressure & float switch settings.			
Check drain system.			
Check safety valve by manually lifting			
Run warm up cycle followed by Leak Rate Test.			
Check the condition of all hoses, plastic pipes and any perishable components for any sign of degradation. Replace parts if signs of wear or degradation found.			
Check safety valve/s for correct operating pressure. See manual.		NA	
Check water tank (if fitted) is clean of debris. Check condition of water inlet ball valve.		NA	
Clean and inspect the condition of all strainers		NA	
Clean and inspect steam traps. Renew parts as required		NA	
Check condition of non-return valves. Renew seats as required		NA	
Renew Sterile Air Filter/s		NA	
Replace all 'O' ring and tri-clamp joint seals		NA	
Inspect valve seats, seals and actuators. Replace as required.		NA	
ELECTRICAL CHECKS			
Check the condition and function of all shunt trips			
Check the condition and function of all contactors			
INTEGRAL STEAM GENERATOR (WHERE FITTED)		Quarterly	Annual
Visually check for physical damage.			
Check for leaks. Tighten pipework as required.			
Check operation of blowdown (if fitted)			
Check safety valve by manually lifting			
Check condition of electrical elements and gasket. Tighten if necessary			
Check condition of cables on electrical elements. Tighten if necessary			
FINISH			
Wipe down panels and clean work area			
Enter results and comments in Sterilizer Log Book. Hand back to user.			
Sign out from department. Report any issues to users/manager			
DECLARATION OF TEST/MAINTENANCE PERSON (STERILIZERS)			
Name:-	Signature:-	Date:-	
DECLARATION OF USER			
Name:-	Signature:-	Date:-	

Door Auto/Manual Switch

With the fascia mounted auto/manual switch in the auto position, normal door operations are available. The auto/manual switch in the auto position will energise input IP13 (IP24 for door 2) for normal operation of the door.

With the switch in the manual position, IP13 (IP24 on door 2) not energised, no door operations are available. The manual position should be selected and the key removed from the switch whenever work is undertaken on the door mechanism or when entry into the chamber is necessary.

WARNING – DO NOT ENTER THE STERILIZER CHAMBER WITHOUT FIRST OBTAINING THE KEY FOR THE AUTO/MANUAL DOOR SWITCH, TURNING THE SWITCH TO THE MANUAL POSITION AND REMOVING THE KEY. KEEP IT ON YOUR PERSON UNTIL IT IS SAFE TO RETURN THE SWITCH TO THE AUTO POSITION AND FOR NORMAL OPERATION OF THE STERILIZER TO RESUME.

CAUTION – ALL STERILIZERS KEYS SHOULD BE HELD IN SAFE AND SECURED STORAGE. THE ISSUING OF KEYS SHOULD BE AUTHORISED BY THE PERSON/S WHO IS/ARE RESPONSIBLE FOR THE SAFE STORAGE OF THE STERILIZER KEYS.

CAUTION – BEFORE ANY ATTEMPT IS MADE TO WORK ON THE DOOR MECHANISM, BOTH THE STERILIZER ELECTRICAL ISOLATOR (MOUNTED BELOW THE OPERATOR CONTROL KEYPAD) AND THE INCOMING MAINS ELECTRICAL ISOLATOR SHOULD BE TURNED TO THE OFF POSITION AND BOTH LOCKED IN THE OFF STATE.

Door Seal

The door gasket is made from silicone tubing of specific cross sectional area and shore hardness.

Clean the surface of the door seal with a damp cloth, wetted with water, to remove any deposits.

Visually inspect the condition of the door seal checking for any cuts or damage that might affect its ability to seal when the door is in a sealed state. If any doubt exists as to the condition of the door seal, report this to the person responsible for the sterilizer.

CAUTION – WHEN CLEANING OR INSPECTING THE DOOR SEAL, ALWAYS WEAR HEAT PROTECTIVE GLOVES. DOOR AND CHAMBER COMPONENTS ARE LIKELY TO BE VERY HOT AND TO CAUSE BURNS.

SEAL REPLACEMENT

The door seal can easily be removed by sliding a flat blade between the gasket and the seal groove then carefully prising the seal from the groove. Do not use sharp instruments to remove the gasket. The gasket can be pulled out of the groove.

CAUTION – ONLY PROPRIETARY REPLACEMENT DOOR SEALS SHOULD BE USED ON THE STERILIZER TO ENSURE OPTIMUM SEALING AND MECHANICAL PERFORMANCE.

CAUTION – BEFORE REPLACING A DOOR SEAL, PLACE THE DOOR IN THE OPEN POSITION, THEN OBTAIN THE KEY FOR THE DOOR AUTO/MANUAL SWITCH. TURN THE SWITCH TO THE MANUAL POSITION, THEN, REMOVE THE KEY AND KEEP IN A SAFE PLACE UNTIL THE JOB IS COMPLETE AND THE DOOR CAN BE RETURNED TO NORMAL OPERATION.

CAUTION – BEFORE REPLACING A DOOR SEAL, ISOLATE THE STERILIZER FROM THE STEAM SUPPLY.

NOTE – ENSURE THAT THE GASKET GROOVE IS THOROUGHLY CLEAN BEFORE REPLACING A NEW GASKET.

Before inserting a new seal, check the condition of the coiled spring spacer at the bottom of the groove. Replace spring if damaged.

Push in the new seal at the midpoint of each side only, ensuring that equal lengths of seal remain between these points. Gently loop the seal into the groove between these points taking care not to stretch or twist the seal.

To check the performance of the new seal, enter the Maintenance Menu and select Door Operations. The door can be sealed and unsealed repeatedly to check sealing of seal.

Door Maintenance

This section provides details of the maintenance checks required to ensure that the door sealing mechanism and the safety devices related to the operation of the door are working correctly.

The maintenance checks should be carried out on a weekly basis and evidence that the checks have been completed should be entered into the sterilizer maintenance log book.

WARNING – BEFORE CARRYING OUT THE WEEKLY SAFETY CHECKS READ THIS SECTION OF THE MANUAL, AND THE DOOR OPERATION SECTION, TO BECOME FAMILIARISED WITH THE OPERATION OF THE DOOR AND ITS SAFETY FEATURES.

WEEKLY MAINTENANCE	
ITEM No	DESCRIPTION
1	CHECK CONDITION OF DOOR SEAL.
2	CHECK THE OPENING AND CLOSING OF THE DOOR TO ENSURE SATISFACTORY OPERATION.
3	CHECK DOOR SEALING OPERATION.
4	CHECK DOOR UNSEALING OPERATION.
5	VISUALLY CHECK THE CONDITION OF DOOR MECHANISM COMPONENTS. a) DOOR SUPPORT BARS b) DOOR SUPPORT BAR FIXING SCREWS c) DOOR CYLINDER d) DOOR LIMIT SWITCHES
6	CHECK DOOR RELEASE PRESSURE FOR SYSTEM TRANSDUCER AND PRESSURE SWITCH PS4.
7	CHECK EMERGENCY STOP SYSTEM

WARNING – IF IT BECOMES NECESSARY TO WORK ON THE DOOR MECHANISM OR ITS SAFETY DEVICES, BOTH THE STERILIZER ELECTRICAL ISOLATOR (MOUNTED ON THE STERILIZER FACIA) AND THE INCOMING MAINS ELECTRICAL ISOLATOR SHOULD BE TURNED TO THE OFF POSITION AND BOTH LOCKED IN THE OFF STATE.

WARNING – BEFORE COMMENCING ANY OF THE DOOR SAFETY CHECKS OR MAKING ANY ADJUSTMENTS, FIRST READ THE GENERAL SAFETY INSTRUCTIONS LISTED AT THE FRONT OF THIS MANUAL

These door checks should be performed within the Door Operations sub-menu within the Maintenance Menu.

Door Movement

Enter the Maintenance Menu and select Door Operations. Within the Door Operations Menu operate the door open then closed, checking that the door travels evenly and at a controlled speed. If the door movement is not smooth, travels too fast or too slow, find the cause of problem before placing the machine back into service.

- a) The door should slide at a controlled rate when moving between the open and closed door positions. A pressure regulating valve is fitted to the pneumatics assembly and controls the opening and closing pressure of the door. This would nominally be set at 6 bar maximum to give the best door performance and keeping the crushing force <150NM. The speed of the door can be adjusted by the speed controllers located within the end of the cylinder. The higher the number on the speed controller the faster the door will open or close.
As the door reaches its closed and open positions, the cushioning in the door cylinder should be set to allow the door to come to a controlled stop position.
- b) The door is closed by pressing and holding the door button. Output OP25 is energized, which energizes solenoid valve SV25. SV25 will pass the regulated pressure to the door cylinder to open the door.
- c) When the door open button is pressed from the closed position, output OP24 is energized, SV25 is de-energized and SV24 energized. The air in the cylinder is exhausted at a controlled rate through SV24, the door will close.
- d) When the door travels to the closed position, ensure that there is approximately 2 - 3mm clearance between the door and the door seal groove.
- e) With the door in the fully closed position, and the door cylinder at the end of its stroke, check that door is centrally placed relative to chamber. The door overlap on each side of the door should be equal.

NOTE – WHEN THE DOOR IS IN THE CLOSED POSITION, THE DOOR SHOULD BE CENTRALLY POSITIONED WITH RESPECT TO THE CHAMBER.

Door Sealing and Unsealing

Enter the Maintenance Menu and select Door Operations.

Within the Door Operations Menu seal and unseal the door checking that both operations work satisfactorily.

When the chamber is warm, the seal should slide and make contact with the door within 10 seconds. Pressure switch PS11 will sense that pressure has been attained and send a signal (at typically 0.8bar) to the microprocessor. When the door is sealed, there should be no signs of steam leakage from around the door.

When the door is unsealed and vacuum is applied to the seal groove, the door seal should retract within 10 seconds. Pressure switch PS10 will sense that a vacuum has been attained and send a signal (at typically -0.2bar) to the microprocessor. When this pressure is reached, a further timed period of vacuum is applied to the seal groove before the unsealed condition is displayed.

If either the sealing or unsealing times exceed the above, inspect the system components for possible defects.

Door Supports

Check the condition of the M20 screws that attached the door retaining bars to the sterilizer vessel. These screws should be torqued to 480NM. This should be checked annually. See drawing of door assembly.

Guide Rollers

Check that the guide rollers that support the door on the guide rail are firmly secured to the door support bars. Check that there is no excessive movement or wear on the roller bearings within the guide rollers. See Front Module Assembly drawing at back of this manual.

Door Cylinder

Check the condition of the cylinder. See Door Assembly drawing within this manual.

Limit Switches

When the door is in closed position, check that the electrical limit switch LS08 is depressed by the striker screw. The switch should not be fully depressed; there should be several millimeters of stroke remaining. Also check that the striker screw depresses the pneumatic valve DCV01 to allow control air to pass to the bank of solenoid valves. Again check that the valve is not fully depressed, but operated sufficiently to pass maximum flow of air.

Pressure Interlocks

Check that the door cannot be opened/unlocked until the chamber pressure is to within ± 0.2 bar of atmospheric pressure.

On the completion of a test or process cycle, check that the VDU option to unseal the door is not displayed until the chamber pressure is within ± 0.2 bar of atmospheric pressure. Confirm that this condition is reached by checking both the chamber pressure gauge and the VDU pressure display that is derived from the control transducer.

In addition to the control system transducer sensing that the chamber is within ± 0.2 bar of atmospheric pressure, the pressure switch PS02 is also within ± 0.2 bar of atmospheric pressure to allow the door to unseal. During an operating cycle, use a neon test probe to check that PS02 opens when the chamber pressure is above 0.2 bar – no signal on wire no. 202. During the venting stage of the cycle, as the chamber pressure approaches 0.2 bar, check that PS02 is open but closes when 0.2 bar is reached – a signal appears on wire no. 202.

Door Adjustment

WARNING – WHEN THE DOOR IS IN THE CLOSED POSITION, THE DOOR SHOULD BE CENTRALLY POSITIONED WITH RESPECT TO THE CHAMBER.

1. Make sure the cushioning screws at the ends of the pneumatic cylinder are adjusted to provide cushioning at the ends of the up and down stroke. Turn the screws fully clockwise then back off two turns.
2. Adjust the air pressure regulator that provides air to the cylinder to a setting of 3 barG, so that the door slides evenly open and closed. The door should be halted at the ends of the cylinder stroke by the cushioned ends without excessive shock.
3. With the door in the fully closed position, and the door cylinder at the end of its stroke, check that door is central relative to the chamber. The door overlap at the top and bottom of the door should be equal. **If not equal, check that Support Bolts in the cylinder Support Tie Bar are resting on the floor (see Fig 1).**

Door Switches

Door raised electrical & pneumatic switches should only operate when the door is within 6mm of being fully closed.

1. Raise the door to the fully closed position.
2. Adjust the striker bolt so that the electrical limit switch plunger is depressed by 4mm. Once adjusted, there should be approximately 2mm of stroke remaining on the plunger (See Fig 2).
3. With the electrical switch in the correct operating position, the pneumatic valve striker should be adjusted so that the valve gives full flow without it being fully depressed (See Fig 2).
4. The safety bolt (Fig 3) should be set so that the LED on the sensor is illuminated when the bolt is fully extended and with 2mm > 5mm of clearance between the top edge of the bolt and the bottom face of the safety bolt bracket.

Fig. 1

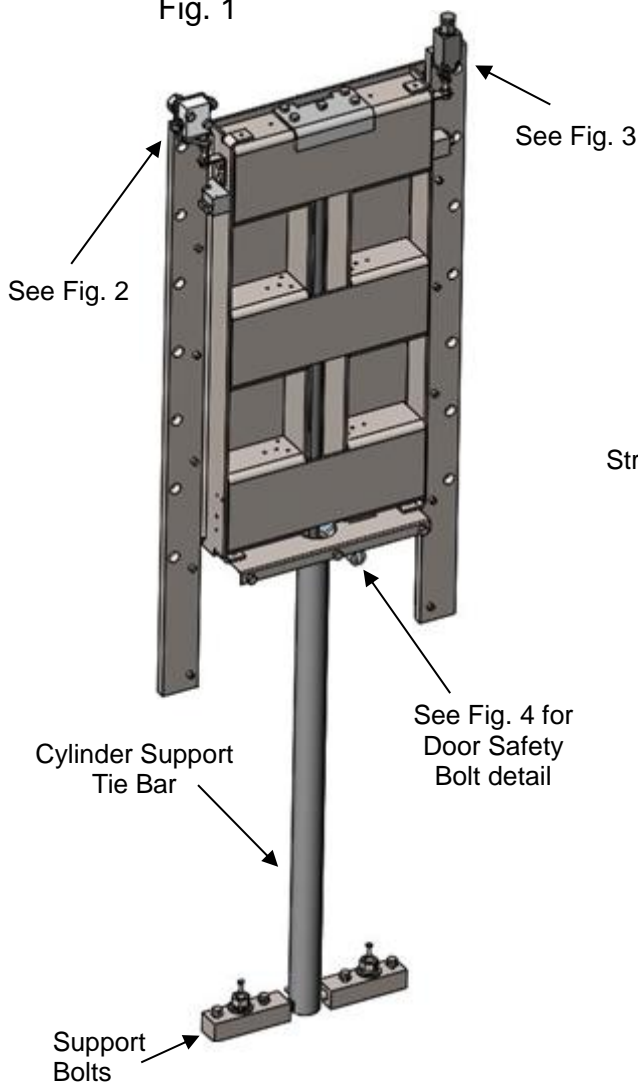

AB3067 Rev. 2

Fig. 2

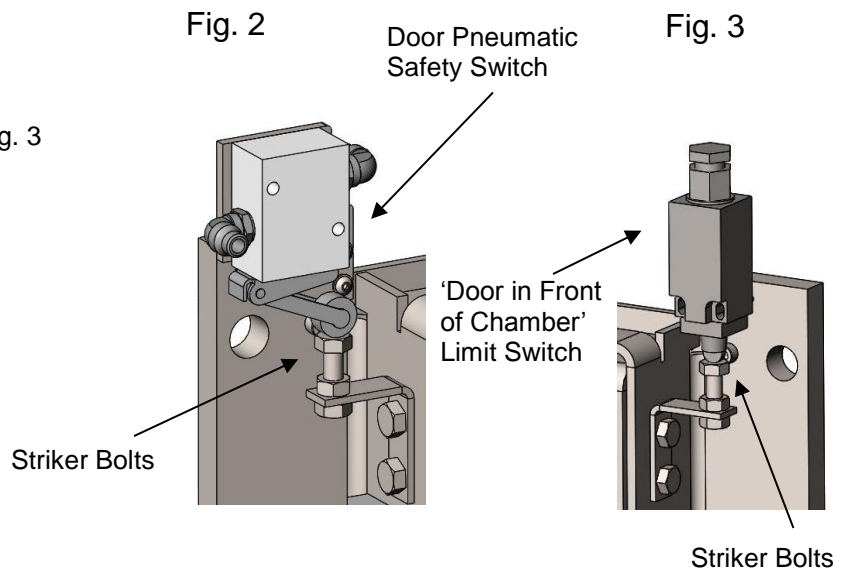

Fig. 3

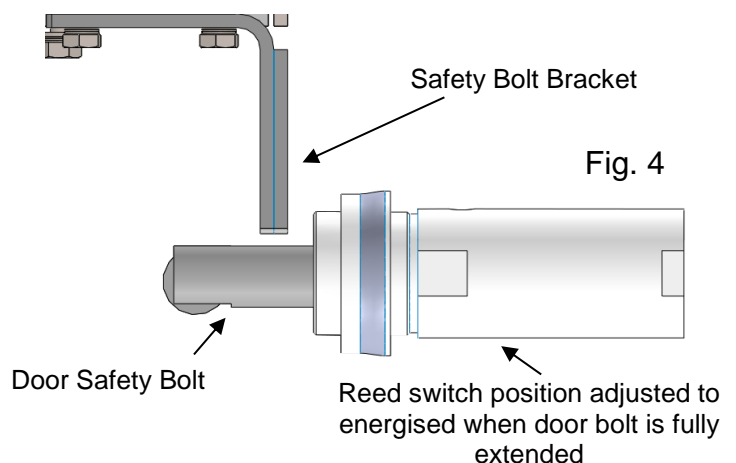

Fig. 4

Calibration

Temperature Channels

The sterilizer temperature channels when fitted with their respective type temperature sensors can be calibrated using the following procedure:

1. Connect the probe to the channel that requires checking and/or calibrating.

All temperature sensors fitted to the sterilizer are either PT100 or PT1000 sensors with a tolerance of $\pm 0.15^{\circ}\text{C}$ for their range of use.

CAUTION – ANY REPLACEMENT TEMPERATURE SENSORS FITTED TO THE STERILIZER SHOULD BE PT100 OR PT1000 SENSORS RATED AT CLASS A OR BETTER.

2. Place the thermocouple into the well of a **TEMPERATURE REFERENCE UNIT (HOT POT)** along with the externally calibrated reference temperature probe. The reference probe should have a current calibration certificate.

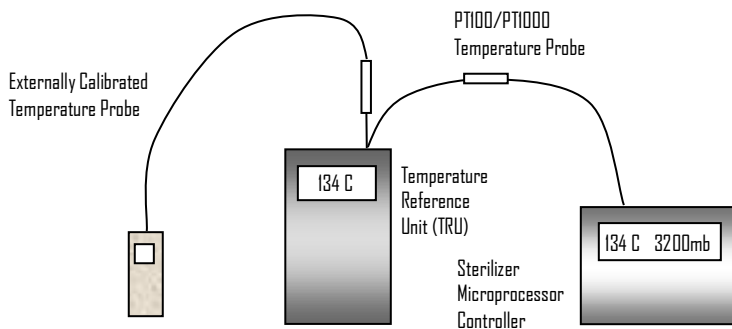

Set the temperature reference unit (TRU) to a temperature of 134°C . Allow time for the unit and thermocouples to stabilise at this temperature – refer to TRU manufacturer’s instructions.

3. Go to the CALIBRATE ANALOG INPUTS within the Maintenance menu. Select the channel to calibrate. Note the temperature being displayed. The displayed temperature should be the same as that shown on the reference temperature thermometer. If an adjustment is required to the displayed value, follow the procedure for calibration as detailed in the calibration section on page 39 of this manual.
5. Transfer the probes to an ice point reference unit and allow to stabilise. If necessary adjust the LOW CAL reading. If an ice point reference unit is not available, set the temperature reference unit to as low a setting as possible, but no greater than 35°C , and CAL LOW at that temperature.

NOTE – REPEAT STAGES 4 & 5 UNTIL NO FURTHER ADJUSTMENTS ARE NECESSARY.

Pressure Channels

The pressure channels on the sterilizer can be calibrated by using an independent pressure calibrator:

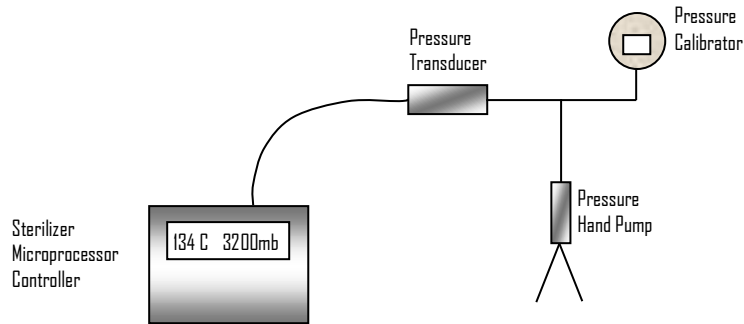

Disconnect the pressure transducer from the cooling coil and connect the **PRESSURE TRANSDUCER** to the **PRESSURE CALIBRATOR** (refer to diagram above) (the calibrator should have a current calibration certificate)

Pull as low a vacuum as possible. The sterilizer vacuum system can be used to produce the vacuum or it can be done off the machine using a hand help pressure/vacuum pump

CALIBRATION EXAMPLE

Channel 1 (TD1) to be calibrated with a Low point of 30mbar (abs) and a High point of 4000mbar (abs)

Enter the Maintenance Menu using a user I.D. and passcode at maintenance level or above.

Select the Analog Inputs sub-menu and then select the Calibrate Pressure option.

<i>Low</i>	Select pressure channel TD1.	[TD1.....0034 mbA <]
	Pull to a vacuum of 30mbar abs using pump and pressure Calibrator TD1 reads 0034 but should read 0030	[TD1.....0034 mbA <]
	To define the low calibration value select the data field and enter the desired value.	[LOW 0030mbA]
	To accept press the Cal Low key. TD1 will now read 0030 mbar abs.	[TD1.....0030 mbar abs]
<i>High</i>	Apply a pressure of 4000mbar abs using pump and pressure calibrator	
	TD1 reads 3990 but should read 4000	[TD1.....3990 mbar abs]
	To define the high calibration value select the data field and enter the desired value.	[HIGH 4000 mbA]
	To accept press the Cal High key. TD1 will now read 4000 mbar abs.	[TD1.....4000 mbar abs]

CALIBRATION

In-Cycle calibration of temperature and pressure channels

The temperature and/or pressure channels on the sterilizer can be calibrated during the running of a cycle. The calibration for the high range of a channel would normally be carried out when the cycle has reached stable conditions during the sterilizing stage. The calibration for the low range of a channel would normally be carried out when the cycle has reached a stable vacuum condition during the drying stage.

1. When the cycle is running, pressing the BMM Weston logo in the top left corner of the screen will cause the I.D. and passcode field to appear.
2. Upon entry of a valid I.D. and passcode at the appropriate level, buttons will appear for Manual Control and In-Cycle Calibration

		Cycle Start Time 14:27:02	DATE Wednesday 09/05/18	TIME 14.31.19
			Expected Cycle Complete Time 15.02.11	
CYCLE 134 FLUID DISCARD		AUTOMATIC CONTROL		CYCLE No. 000028
AUTOMATIC CONTROL		<	>	CYCLE TIME : 00.00.33
STAGE : AIR REMOVAL VACUUM		STAGE TIME : 00.00.33		
EXTENDED		SUB STAGE TIME : 00.00.33		
TEMPERATURE °C			PRESS : mbarA	
VENT V.REF JACK			CHAM CREF	
051.0 051.2 135.5			0020 0021	
AIRD				
← STEP STAGE →				
IN-CYCLE CALIBRATION			ABORT	
EXIT ENGINEER'S FUNCTIONS				
<i>MESSAGE AREA</i>				

3. Selecting "Manual Control" will cause three buttons to appear, the left and right Step Stage buttons allow the user to step backwards or forwards through the programmed stages of a cycle. The Automatic Control button will return the cycle to automatic operation.

CALIBRATION

4. Selecting In-Cycle Calibration will cause the lower half of the screen to display calibration adjustment options. The cycle will also be put into manual control so that the machine does not change stage whilst calibration is being carried out.

In-Cycle Calibration									
PRESSURE CHANNELS			LOW (ZERO) ADJUSTMENT						
			DOWN				UP		
TD1 CHAMBER	XXXX mbA		↓ SMALL		↓ LARGE		↑ SMALL		↑ LARGE
TD2 CHAM REF.	XXXX mbA		↓ SMALL		↓ LARGE		↑ SMALL		↑ LARGE
TD3 AIR DETECTOR	XXXX mbA		↓ SMALL		↓ LARGE		↑ SMALL		↑ LARGE
TD4 JACKET	XXXX mbA		↓ SMALL		↓ LARGE		↑ SMALL		↑ LARGE
TD5 BOILER	X.X BarG		↓ SMALL				↑ SMALL		
SELECT CAL HIGH/LOW (SPAN/ZERO)			CAL LOW (ZERO)		↓				
TEMPERATURE CHANNELS			OFFSET (X10)		OFFSET ADJUSTMENT				
TC1 VENT	XXX.X °C		XXX		↓ -0.1°C				↑ +0.1°C
TC2 VENT REF.	XXX.X °C		XXX		↓ -0.1°C				↑ +0.1°C
TC3 JACKET	XXX.X °C		XXX		↓ -0.1°C				↑ +0.1°C
TC8 BOILER	XXX.X °C		XXX		↓ -0.1°C				↑ +0.1°C
SAVE AND EXIT			CONTINUE WITHOUT SAVING						
CHAMBER PRESSURE	0959mb	BOILER PRESSURE	4.5bar	JACKET TEMPERATURE	135.3°C				
JACKET PRESSURE	3160mb			LAST CYCLE NUMBER	000101				
DOOR 1 LOADING SIDE					DATE	Wednesday 09/05/2018	TIME	10:26:28	

5. From this screen calibration can be carried out as usual, if a temperature channel is being calibrated the temperature value can be incremented by +0.1°C or -0.1°C.
6. If a pressure channel is being calibrated, the Small key will increment the pressure by +1mbA or -1mbA for TD1-TD4 or 0.1barG for TD5. The Large key will increment the pressure by +10mbA or -10mbA for TD1-TD4.
7. After calibration, exit the in-cycle screen to continue the cycle. The cycle will be displayed as a fail.

Printer

3. PRINTER OPERATION

Printer Thermal Paper
Part No. – **H15746**

3.1 Mode Button and Status LED Operation

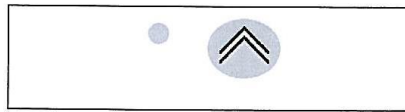

Status LED Mode Button

3.2 Power On Self Test

The self test procedure is initiated by supplying power to the printer while the mode button is depressed. When the mode button is released a test print will be produced.

3.3 Status LED

The printer incorporates an LED indicator to report its condition. If there is a fault, the LED will flash in sequence. The fault can be identified by counting the number of flashes.

LED Indication	Condition	Solution
On	Printer On	-
Off	Printer Off	-
* * *	Paper out or door open	Fit new paper
** ** **	Thermal head too hot	Allow head to cool

3.4 Paper Out

The printer will automatically detect when the printer paper has run out, and report this using the Status LED. Use the Mode button to feed through the last few centimetres of paper and fit a new roll.

3.5 Head Thermal Limit

After extensive printing the print head temperature may rise to an unusable level. The Status LED will report when this occurs, and printing will be suspended until the head temperature returns to normal levels.

3.6 Paper Tear Procedure

When removing printout from the printer, pull the printout toward the tear bar and tear from one side to the other across the serrated edge.

3.7 How To Open Lid

Pull the lever until the lid is released from its locked position. To avoid damage do not use excessive force.



3.8 Replacing Paper Roll

If the paper roll needs replacing, open the paper cup lid and remove the remaining paper. Reel off a few centimetres from a new roll of paper. Hold approximately 5cm of paper outside the device as you place the new roll into the reservoir. Close the lid by applying equal amounts of pressure on each side ensuring the lid is in the locked position. Now tear the spare paper away.

3.9 Paper Feed

Depressing the mode button will allow paper to be fed through the printer.

PRINTER CONNECTIONS

MPP5610, MPP5611 & MPP5620

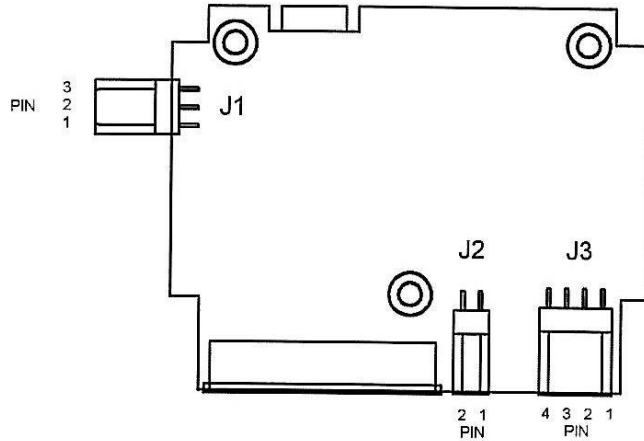

J1 Take-Up spool connection (optional)
Customer connector Molex ref 2201 2035
plus Molex crimp, ref 0850 0032 (2 off)

Pin No	Use
1	N/C
2	-ve
3	+ve

J2 Power connection
Customer connector Molex ref 2201 2025
plus Molex crimp, ref 0850 0032 (2 off)
wire size 22 AWG

MPP5610, MPP5611	
Pin No	Use
1	0v
2	5vdc

MPP5620	
Pin No	Use
1	0v
2	24vdc

J3 Interface connection
Customer connector Molex ref 2201 2045
plus Molex crimp, ref 0850 0032 (4 off)
wire size 24-30 AWG
(USB-B optional)

Pin No	Use
1	RXD In
2	TxD Out
3	CTS
4	GND

MPP5610V

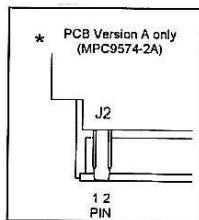
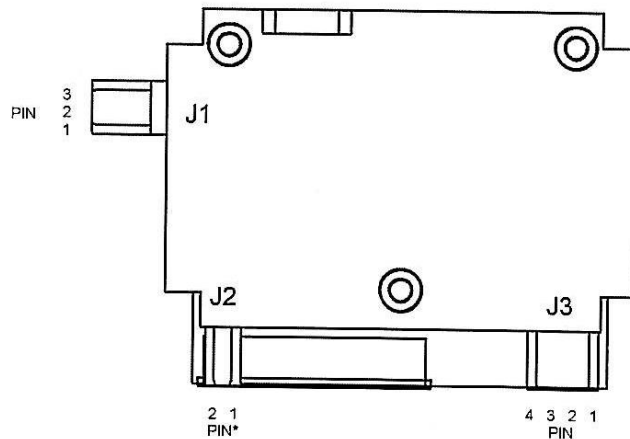

J1 Take-Up spool connection (optional)
Customer connector Molex ref 2201 2035
plus Molex crimp, ref 0850 0032 (2 off)

Pin No	Use
1	N/C
2	-ve
3	+ve

J2 Power connection
Customer connector Molex ref 2201 2025
plus Molex crimp, ref 0850 0032 (2 off)
wire size 22AWG

Pin No	Use
1	0v
2	10-35v

J3 Interface connection
Customer connector Molex ref 2201 2045
plus Molex crimp, ref 0850 0032 (4 off)
wire size 24-30AWG
(USB-B optional)

Pin No	Use
1	RXD In
2	TXD Out
3	CTS
4	GND

Printer configuration

The printer incorporates a number of configurable *options*, each of which has a number of *settings*. The default settings of the standard printer are detailed in the table below in bold. To change the setting of any option, follow the procedure below:

1. Ensure the printer is OFF.
2. Press and hold the Mode button whilst powering the printer ON. After about five seconds, the Status light will flash five times to show that the printer is in *configuration mode*. Release the Mode button.
3. Press the Mode button the same number of times as the *option* that you wish to change (for example to change baud rate, press the Mode button twice).
4. After a short delay, the Status light will flash the same number of times as the option that you have chosen. If you have made a mistake at this stage, simply wait: after a delay, the printer will power-on without changing any options.
5. To proceed with configuration, press the Mode button the same number of times as the *setting* that you wish to make (for example, to set the baud rate to 19200, press the Mode button once).
6. After a short delay, the Status light will flash the same number of times as the setting that you have made.
7. After a further delay, the printer will power-on with the new setting.

Option Number	Option	Setting Number (default in bold)	Setting MPP5610 & 5611 (default in bold)	Setting Number	Setting MPP5620 (default in bold)	
1	RS232 Protocol	1	8, No parity			
		2	8, Odd parity			
		3	8, Even parity			
		4	7, Odd, parity			
		5	7, Even Parity			
2	RS232 Baud Rate	1	19200 baud	1	115200 baud	
		2	9600 baud	2	57600 baud	
		3	4800 baud	3	38400 baud	
		4	2400 baud	4	19200 baud	
		5	1200 baud	5	9600 baud	
		6	600 baud	6	4800 baud	
		7	300 baud	7	2400 baud	
					8	1200 baud
					9	600 baud
					10	300 baud
3	RS232 Handshake	1	None			
		2	Software			
		3	Hardware			
4	Default Font	1	Arial 16, 24 CPL			
		2	Arial 12, 32 CPL			
		3	Arial 8, 48 CPL			
5	Character Format	1	Normal			
		2	Double Width			
		3	Double Height			
		4	Double Width and Height			
6	Print Density	1	Lowest			
		2				
		3				
		4	Highest			
7	Printer Current	1	Highest			
		2				
		3				
		4	Lowest			
8	Print Format	1	Standard paper, upside down			
		2	Standard paper, normal			
		3	Labels, normal printing			
		4	Labels, upside down printing			

Integral Electrical Steam Generators

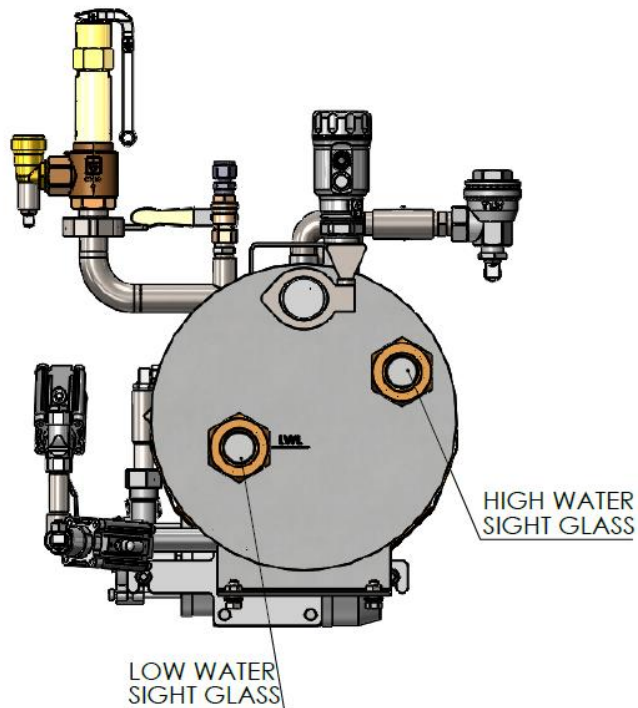
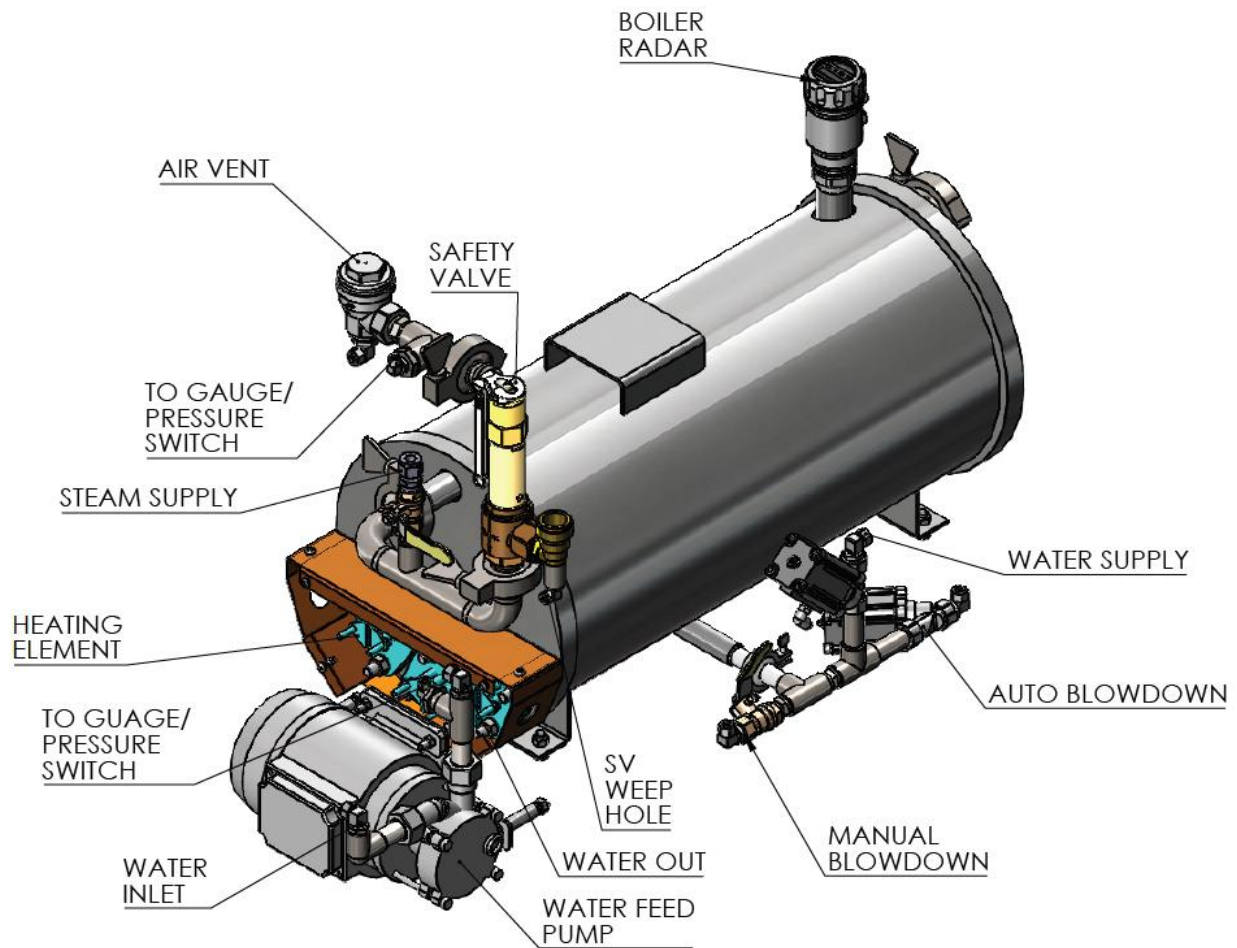

Rear view of boiler shell

INTEGRAL STEAM GENERATOR

The Integral Steam Generator comprises a 316L stainless steel shell with end plates and fitted with 3 electrical heating elements. The elements will be 6 kW each to give a total heating load of 18 kW. The generator is controlled by the sterilizer control system. The generator must be supplied with either softened or purified water. RO water is preferred because it will supply the sterilizing cycle with cleaner steam, and will substantially reduce deposit formation within the generator. The generator and associated equipment will stay cleaner and will require less frequent blowdown. All associated pipework and components are in 316L stainless steel to meet the demands of clean steam.

NOTE - SOFTENED WATER WITH A HARDNESS NOT EXCEEDING 5 PPM (AS CALCIUM CARBONATE) MUST BE SUPPLIED TO THIS STEAM GENERATOR.

THE BLOWDOWN FREQUENCY SHOULD BE SET TO A MINIMUM OF 3 SECONDS AT THE END OF EACH CYCLE FOR A SERIES 1 STERILIZER.

FAILURE TO MAINTAIN THIS QUALITY MAY AFFECT WARRANTY

Integral Generator Operation

1. From empty and the generator enabled from the sterilizer control panel, the water pump and solenoid valve SV83 will be energized. SV83, mounted on the sterilizer pneumatic solenoid, will open and pressurize the air-line to valve V83.
2. The water inlet valve V83 will open and water will be pumped into the generator. Before entering the generator, the water will flow through a non-return valve NRV. This valve will provide protection against reverse flow when the generator is at working pressure.
3. As water fills the generator and the low water level float FS6 is raised, input IP14 to the control system is energized. The heating elements will now be turned on to heat the water. A miniature circuit breaker 3MCB, housed in the generator control box, provides protection for an excess current condition on electrical heated elements.
4. Water will now fill the vessel until the pump on/off float switch FS5 is raised. Input IP12 to the control system is de-energized. The water inlet valve V83 will close and the water pump will stop.
5. When the steam pressure within the generator reaches 4.5 barG as sensed by the pressure transducer TD5, the elements will be switched off. When the pressure fall to 4.2 barG, 0.3 bar differential, the elements are switched on.
6. By using steam, the water level will fall. When the level falls below a predetermined amount(FS5), the boiler radar switching output will close, input IP12 to the control system is energized. The water pump will again run and the water inlet valve shall open to fill the generator to the pump radar raised position. To minimize the effects of turbulence within the generator the contact within the switching output must either be continuously open or closed for a period of 5 seconds before any action is taken.
7. Boiler radar switching output 2 FS4 must be closed, input IP13 to the control system is energized, before a new cycle can be selected. This signifies that there is sufficient water in the generator to complete a full cycle. Once the cycle has started, the state of the switch is ignored.
8. On initial filling from cold, the air vent will be open to allow the displacement of air from within the boiler. As steam is generated and contacts the capsule within the air vent, the vent will progressively close. During the normal operation of the generator, air and non-condensable gases will be liberated from the water. These gases will rise, and on reaching the air vent will cool the capsule. The air vent will partially open to dispel these gases and close again when heated steam reaching the capsule.
9. The water inlet pressure gauge displays the water pump pressure. A steam pressure gauge is connected to the generator shell.
10. The sight glass shows the level of the water within the generator and the high/low level positions of the radar.
11. A pressure switch is fitted and set to operate at 5.8 barG. If the pressure in the generator were to exceed this value, input IP15 to the control system would be energized and the generator control would proceed to a lockout status. The heating elements would turn off immediately and the generator would not restart until the lockout is reset. Before resetting the lockout, an engineer would first need to establish the cause for, and fix, the problem. The lockout can then be cancelled in the boiler section of the maintenance menu.
12. The safety valve is pre-set to open at 6.3 barG.

WARNING— THE VALVE MUST BE PIPED TO A SAFE DISCHARGE LOCATION.

13. The automatic blowdown valve (if fitted) should be connected to a suitably sized blowdown separator. The sterilizer control variables QC, QD and QE determine blowdown frequency. Blowdown will automatically occur at the end of each cycle providing QC and QD are not programmed 0. QC sets the overall blowdown time, QD sets the pulse on time and QE the pulse off time. For softened water with a TDS of 300ppm and allowing for a ½" pipe, 7m long, between blowdown valve and blowdown separator, initial settings for the variables could be QC = 6 seconds, QD = 0.5 seconds and QE = 2 seconds. The generator water TDS should be monitored periodically and, if necessary, adjustments made to these settings.
14. When using RO water, it is unlikely that the generator will be connected to a blowdown separator. If a blowdown separator is fitted, use blowdown frequency as 13 above. If no automatic blowdown employed, it is recommended that at the end of each working week, the generator is switched off and allowed to cool. With the generator at atmospheric pressure the manual drain valve can be opened to drain the vessel. When drained, close the manual valve. When the generator is next turned on, the vessel will fill with fresh RO water.

Replacement and checking of Heater Elements

Warning - Isolate the plant steam supply to the steam generator and remove air supply to V96 (plant steam to generator valve). Applicable to steam heated generators only.

Warning - Isolate the electrical supply to the sterilizer and the steam generator. This may be a single supply to both or individual supplies

Warning – Within the generator control box, switch the electrical heaters MCB to the off position. Applicable to electrically heated generators only.

Warning – Before attempting to remove an element, ensure that there is no pressure within the generator, the generator is fully drained, and the temperature of the parts to be removed are safe to handle.

1. Remove the cover that protects the electrical elements (electrical elements only).
2. Electrically disconnect the wires attached to the element (electrical elements only).
3. The resistance of the element can be checked at this point. The 6kW (part no. H18169) element should have a resistance of 28 Ohms.
4. Unfasten plant steam supply & condensate return pipework from steam element (steam heated only).
5. Unfasten the nuts that secure the elements to the generator endplate.
6. Slide the element horizontally to remove it from the generator shell.
7. Before replacing an existing or new element, ensure generator face and element flange are cleaned.
8. Fit a new gasket, part no. H17181 for electric element & H12571 for steam element before sliding the element back into the generator.
9. Apply copper slip paste to the studs before replacing the washers and nuts.
10. Do not over tighten the nuts on re-assembly. A recommended torque of 35Nm should be used on M10 nuts (electric elements) and a torque of 140Nm on M16 nuts (steam elements).

Boiler Radar Assembly

The boiler radar assembly comprises of a steel probe placed in the boiler tank on a vertical stem. To check the operation of the radar, start from a drained generator condition, then:

1. From the Maintenance menu, start the boiler. Once started, navigate to the boiler inputs menu.
2. The boiler will start to fill with water. As the water rises in the sight glass observe the point at which the switch point displays on the radar as shown below. At the point check that the screen input status for a changed state.
3. Similarly check that the Water too Low changes status when the display shows, and the Water stop/start fill changes status when the display shows the following:
 IP12 = Boiler water stop/start fill.
 IP13 = Boiler water to stop cycle.
 IP13 = Boiler low water.

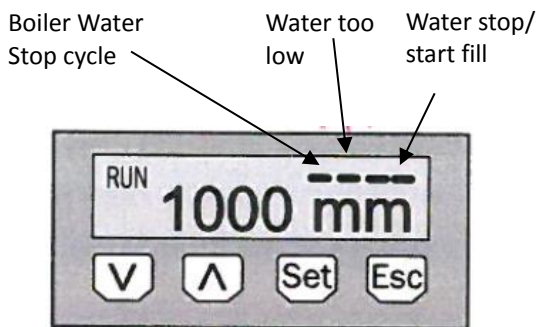

Safety Valve and Overpressure checks

The pressure of the generator is controlled between 4.2 bar to 4.5 bar. If the generator control pressure is exceeded by a pre-set value a lockout condition will occur:

1. The over-pressure pressure switch PS15 reaching 5.5 bar.
2. The control transducer seeing a pressure of 5.8 bar.

In a lockout condition, the heating elements will be turned off and all generator functions will stop. The fault condition will be displayed on the operator display unit.

To test the operation of the over-pressure controls, proceed as follows:

Warning – This procedure should be only undertaken by suitably qualified maintenance persons.

Warning – During the procedure live electrical terminals will be exposed.

- a. Gain access to the electrical heaters contactor 1CA/B/C. With the generator operating normally, out of cycle, and at working pressure, manually operate contactor 1CA/B/C to keep the elements closed. The generator pressure will begin to rise. Observe the generator pressure gauge and/or the digital display on the operator terminal. When the pressure is within the range 5.35 bar to 5.65 bar, the generator should go to lock-out. Re-adjust the pressure switch if it does not operate within this range.
- b. To test the control transducer setting, input from pressure switch PS15 must be removed. On the sterilizer relay board, disconnect wire no. 219 from the pressure switch. Repeat procedure as in b) above, the generator should now lock out at 5.8 bar.
- c. To test the setting of the safety valve, repeat b) above, but ignore any lockout condition. Carefully observe the pressure within the generator whilst keeping contactor 1CA/B/C manually operated. The safety valve should begin to pass steam at approximately 6.3 bar. If the pressure does not start to relieve before a pressure of 6.45 bar is reached, release the contactor 1CA/B/C to de-energise the heating elements.
- d. If the safety valve does not open, turn off the mains supply to the sterilizer and generator and allow the generator pressure to decay to atmospheric. The safety valve can now be removed for inspection and pressure testing. Resetting the safety valve should only be performed by a competent person/organization.

INTEGRAL STEAM GENERATOR

Steam Generator Control Menus

On selecting "AUXILIARY MENUS", VDU displays the options as below:-

Auxiliary Menu Selection					
SUPERVISOR MENU		MAINTENANCE MENU			
VALIDATION MENU		CONFIGURATION MENU			
ERROR HISTORY		CYCLE LOG STORE MENU			
BOILER CONTROL MENU		EXIT			
CHAMBER PRESSURE	0959mb	BOILER PRESSURE	4.5bar	JACKET TEMPERATURE	135.3°C
JACKET PRESSURE	3160mb			LAST CYCLE NUMBER	000101
DOOR 1 LOADING SIDE		DATE	Wednesday 09/05/2018		TIME 10:26:28

On selecting BOILER CONTROL MENU, VDU displays the options as below:-

Boiler Control Menu					
	CURRENT STATUS	AT LAST LOCKOUT			
BOILER IS RUNNING	NO	NO			
WATER IS AVAILABLE TO FEED BOILER	YES	YES			
WATER IS WITHIN THE CONTROLLED HIGH LEVEL BAND	NO	NO			
WATER LEVEL IS ABOVE THE MINIMUM LOW LEVEL	NO	NO			
WATER PUMP OVERLOAD HAS TRIPPED	YES	YES			
BOILER IS IN LOCKOUT MODE	YES	YES			
BOILER OVER PRESSURE DETECTED - PRESSURE SWITCH	NO	NO			
BOILER OVER PRESSURE DETECTED - TRANSDUCER	NO	NO			
BOILER LOW WATER LEVEL DETECTED	NO	NO			
BOILER OVER TEMPERATURE DETECTED	NO	NO			
BOILER MCB SHUNT TRIP HAS BEEN OPERATED	YES	YES			
BOILER MCB HAS TRIPPED (BANK 1, 2, 3)	NO NO NO	NO NO NO			
OVERFILL/WATER LEVEL SENSOR ERROR	NO	NO			
EMERGENCY SWITCH HAS BEEN OPERATED	NO	NO			
AIR SERVICE FAILED	NO	NO			
FILLING WATCHDOG TIMEOUT	NO	NO			
HEATING WATCHDOG TIMEOUT	NO	NO			
HEATER CONTACTOR FAILED CLOSED (BANK 1, 2, 3)	NO NO NO	NO NO NO			
HEATER CONTACTOR FAILED OPEN (BANK 1, 2, 3)	NO NO NO	NO NO NO			
START BOILER		EXIT			
CHAMBER PRESSURE	0959mb	BOILER PRESSURE	4.5bar	JACKET TEMPERATURE	135.3°C
JACKET PRESSURE	3160mb			LAST CYCLE NUMBER	000101
DOOR 1 LOADING SIDE		DATE	Wednesday 09/05/2018		TIME 10:26:28

The Boiler Control Menu displays the status of boiler flags. These will be coloured red if their status will prevent the boiler from running and green if not.

If the boiler is running, the Start/Stop Boiler button will read Stop Boiler, if the boiler is not running, the button will display Start Boiler.

On selecting Stop Boiler, send stop signal to the boiler.

On selecting Start Boiler, the system will check the status of boiler flags to ensure it is safe/possible to start the boiler. Any reason that would prevent the boiler from starting will be reported on the display. If all checks are passed, a start signal is sent to the boiler. On selecting Exit, the menu returns to the Auxiliary Menus screen.

Drawings and Parts List

Valve Island & Air Preparation Set.

Located on Gauge Panel at the rear of machine
 For Air circuit refer to Pipe work Schematic located within this Manual.

Valve Island (H23535)

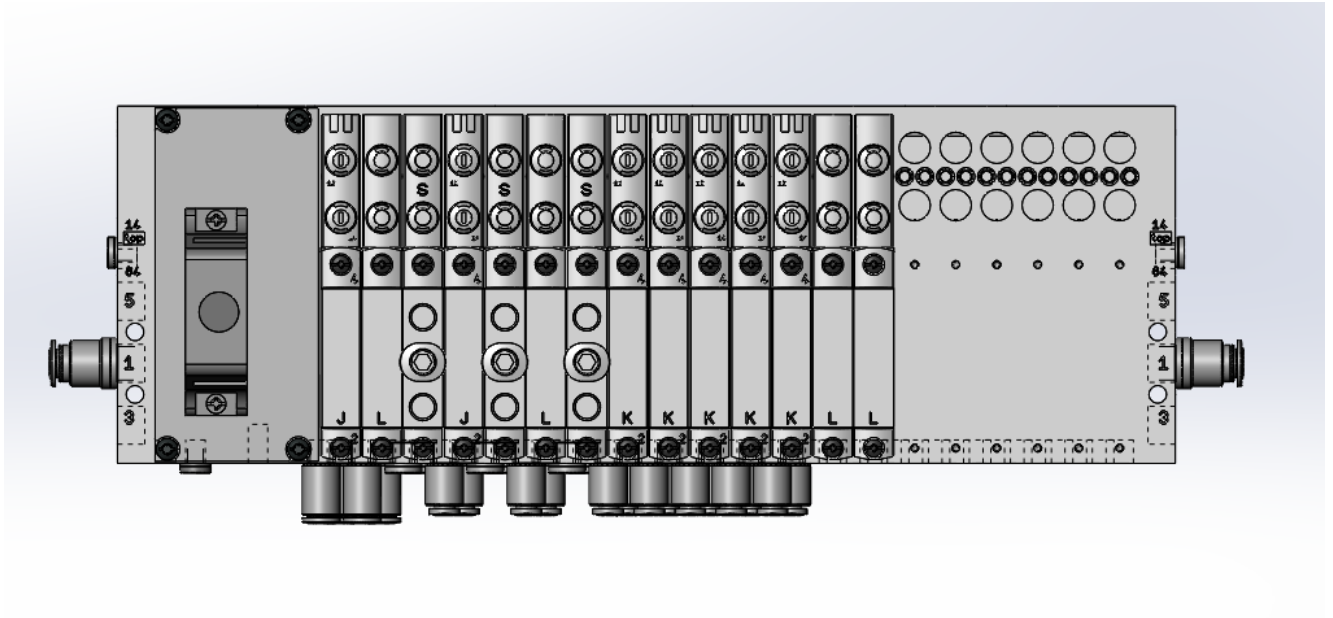

Air Preparation Set (H21516)

AIR ISOLATION VALVE.
BMM PART No. TBC

FILTER ELEMENT
BMM PART No. TBC

AIR REGULATOR (SET AT
6BAR MAX.)
BMM PART No. TBC

AIR SERVICE PRESSURE
SWITCH/GAUGE
BMM PART No. TBC

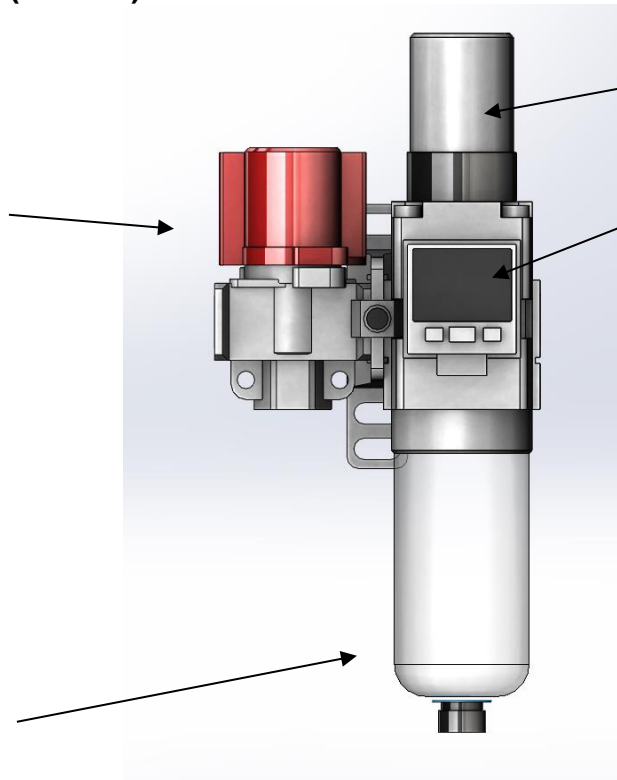

Control Valves - Burkert

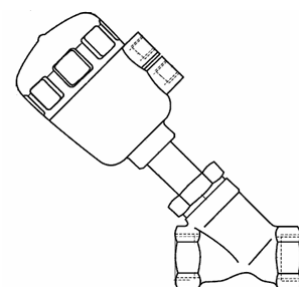
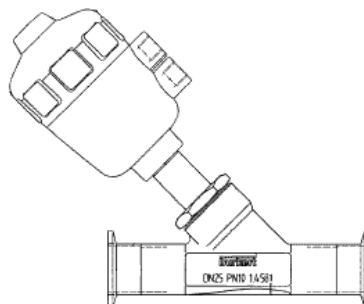
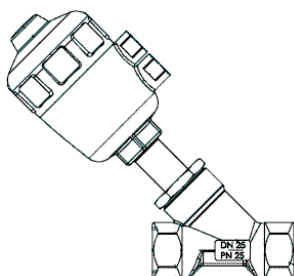
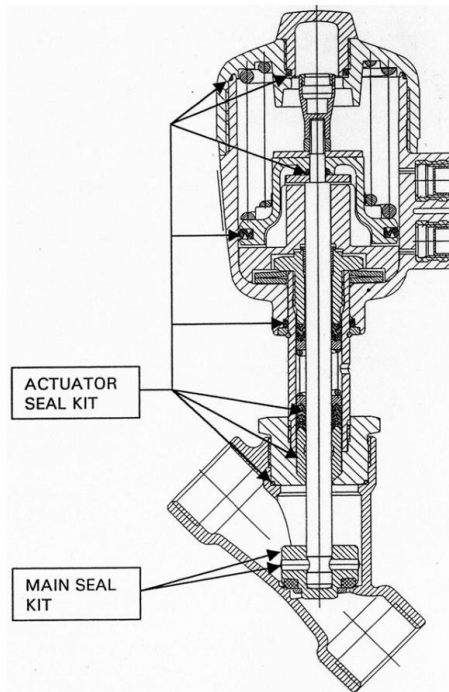

SPARE PARTS

SCREWED PROCESS VALVE (Head dia 65mm)				*APPLIES TO SCREWED AND TRI- CLAMP*		TRI-CLAMP PROCESS VALVE (Head dia 65mm)			COMPACT PROCESS VALVE (Head dia 50mm)		
Size	Func	BMM Part No's				Seal Kit	Actuat or Kit	Size	Func	Part No.	Size
		Brass	ST.ST.								
1/2"	NC	H7810	H8019	DS586	DS575	DN15	NC	H9553	1/2"	NC	H9114
1/2"	NO	H7811	H7221	DS586	DS575	DN15	NO	H11206	1/2"	NO	H9115
3/4"	NC	H7812	H7222	DS587	DS575	DN20	NC	H9463	Seal Kit- DS586 Actuator kit- DS634		
3/4"	NO	H7813	H8020	DS587	DS575	DN20	NO	H9464			
1"	NC	H7814	H8021	DS588	DS576	DN25	NC	H9995	NC- Normally Closed NO- Normally Closed		
1"	NO	H7815	H8022	DS588	DS576	DN25	NO	H10101			
1.1/4"	NC	H7816	H7223	DS589	DS576	DN32	NC	H9462			
1.1/4"	NO	H7817	H8024	DS589	DS576	DN32	NO	H10102			
1.1/2"	NC	H7818	H8023	DS590	DS576	*THIS SIZE NOT USED*					
1.1/2"	NO	H7819	H8025	DS590	DS576	*THIS SIZE NOT USED*					

Control Valves - SMC

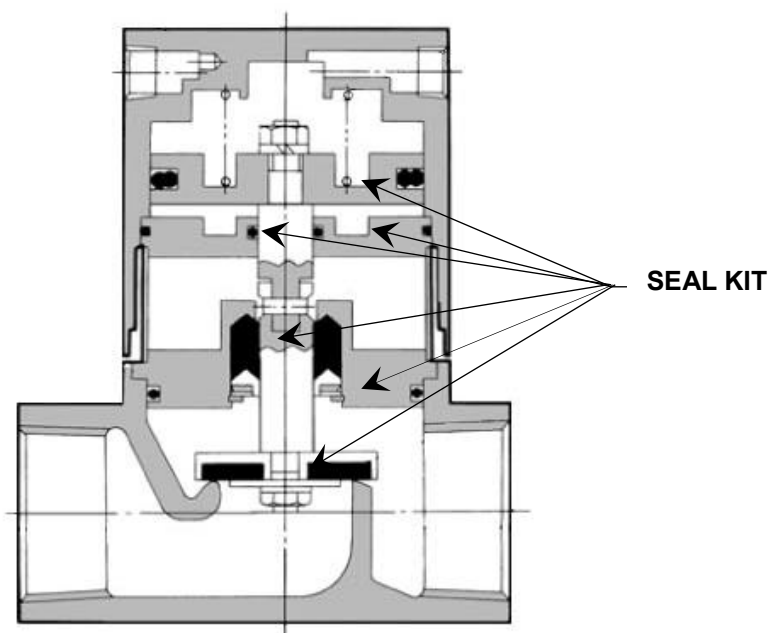

Valve Part No.	Description	Seal Kit No.
H16498	3/8"BSP (DN10) NC ST.STL. VND Valve	DS767
H16007	3/8"BSP (DN10) NO ST.STL. VND Valve	DS767
H16589	1/2"BSP (DN15) NC ST.STL. VND Valve	DS768
H17043	1/2"BSP (DN15) NO ST.STL. VND Valve	DS768

Strainers

To identify the replacement screen/mesh required, determine the part number of the line strainer from the sterilizer pipework schematic, then refer to the table below:

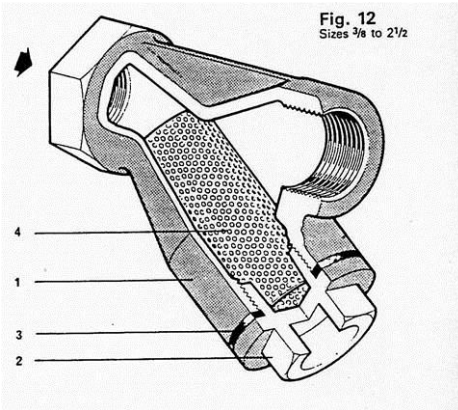

Size	BMM Part No.	Material	Mesh Size	Spare Mesh Part No.
1/2" BSP	H10059	Brass	1/32"	H10060
1/2" BSP	H3447	Brass	100	H10061
1/2" BSP	H7284	Stainless Steel	60	DS748
3/4" BSP	193305	Brass	1/32"	060104
3/4" BSP	H3311	Brass	100	H3310
3/4" BSP	H7285	Stainless Steel	60	DS749
1" BSP	H10062	Brass	1/32"	H10063
1" BSP	H10064	Brass	100	H10065
1" BSP	H7286	Stainless Steel	60	DS750
1 1/4" BSP	H10066	Brass	1/32"	H10067
1 1/4" BSP	193303	Brass	100	H10068
1 1/4" BSP	H7287	Stainless Steel	60	DS751
1 1/2" BSP	H8847	Brass	1/32"	H10069
1 1/2" BSP	H1923	Brass	100	H10070

Pressure Switches

BMM Ref.	BMM Part No.		Pressure Range	Factory Setting	Application	'O' Ring Part No.
	Brass	S/steel				
PS1	H11450	H11451	0.35 to 7 bar	+4.5 bar	Air service	DS507
PS2	H11450	H11451	0.35 to 7 bar	+2.0 bar	Steam service	DS507
PS4/5	H12138	H11452	-1 to 0.5 bar	+0.2 bar	Chamber Safety	DS507
PS8	H11453	-	-1 to 4 bar	-0.2 bar	Door unseal	DS507
PS9	H11453	-	-1 to 4 bar	+0.8 bar	Door seal	DS507
PS10	H11450	H11451	0.35 to 7 bar		Door safety edge	DS507

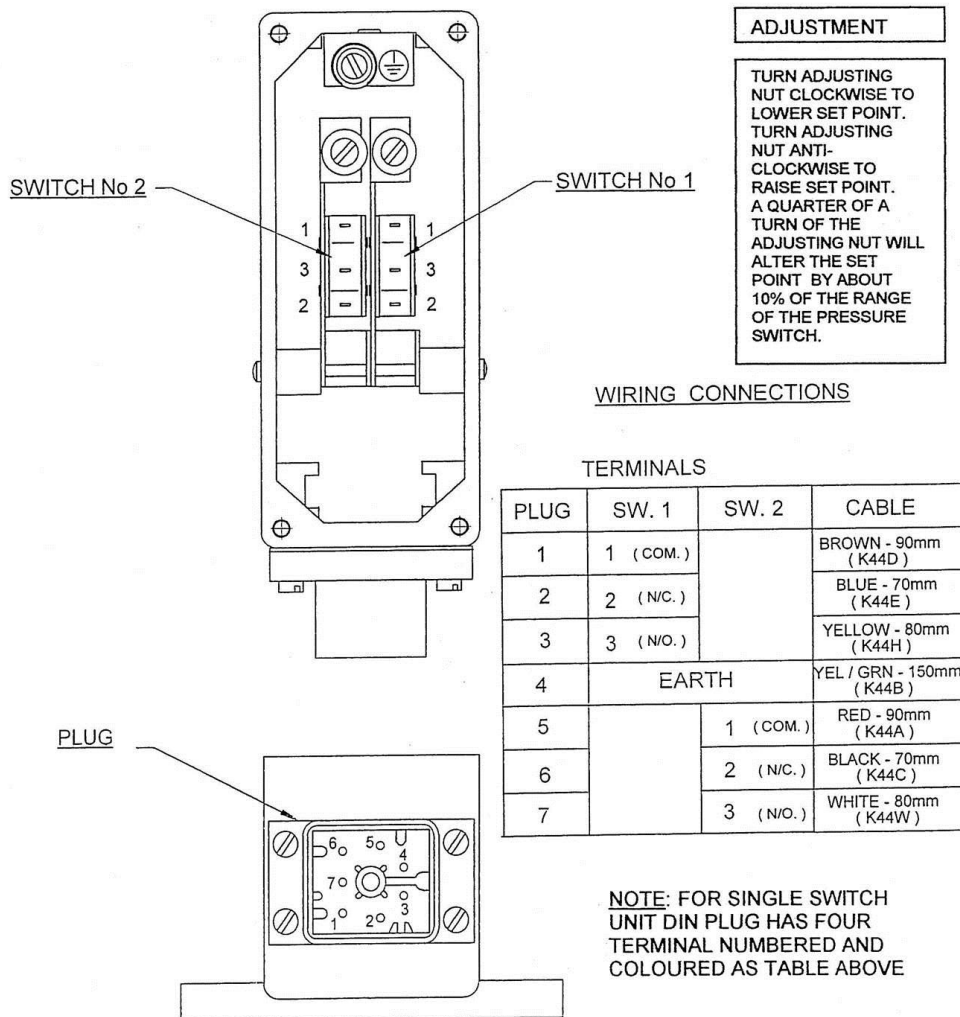

Steam Trap

BPT13SX Balanced Pressure Thermostatic Steam Trap
Installation and Maintenance Instructions

Description

BPT 13 SX Straight connection with strainer screen
 The standard capsule is marked with the letter (E).
 Other options can be supplied for near to steam (G)
 or sub cooled (F) operation.

Limiting conditions (to ISO 6552)

Body design conditions PN16.
 PMA — Max. allowable pressure 16 barg.
 TMA — Max. allowable temperature 260°C.
 Cold hydraulic test pressure 24 barg.
 PMO — Max. operating pressure 13 barg.

Installation

The trap is designed for installation with the capsule
 in a horizontal plane and the cap at the top,
 preferably with a drop leg immediately preceding
 the trap.

How to fit

Allow to cool, remove cap and lift out spring, old
 capsule and spacer plate. Remove valve seat,
 strainer screen and gasket. Screw in new seat,
 strainer screen and gasket. Drop in spacer plate.
 Replace new capsule and spring, screw on cap
 using new gasket.

Always fit complete assembly when replacing the
 capsule.

Recommended tightening torques

Cap (2) 90/110 Nm 50mm A/F
 Seat (B) 35/40 Nm 17mm A/F

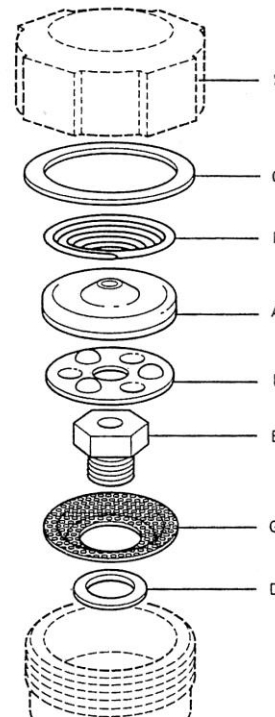
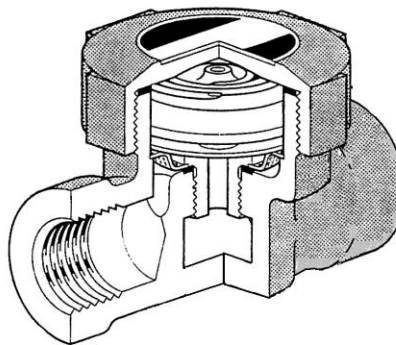

Size	BMM Part No.	Spares Kit Part No.
1/2" BSP	H4848	DS 510

Tri-clamp Seals

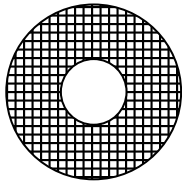

1/2"
27 OD x 9.5 ID
H9187

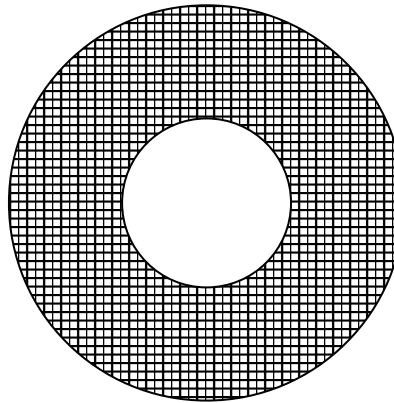

1"
52 OD x 22 ID
H9189

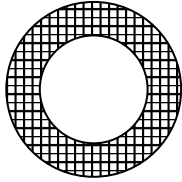

3/4"
27 OD x 16 ID
H9188

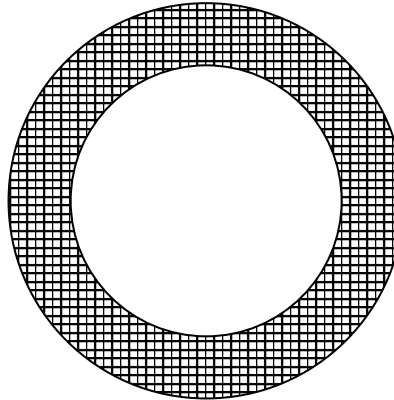

1 1/4"
52 OD x 35 ID
H9190

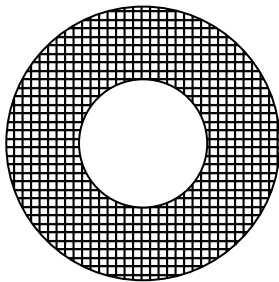

34mm
36 OD x 16 ID
H9716

O – Ring Seals



190608 10 od x 4 id Gauge O-ring & Fan Reed Switch

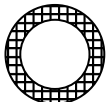

190623 (6mm O-ring) 13 od x 9.3 id Pipework General

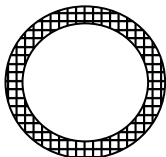

190625 (15mm O-ring) 21 od x 15 id Pipework General

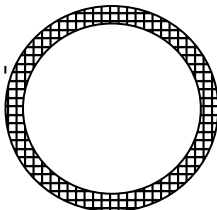

190616 (22mm O-ring) 27 od x 22 id Pipework General

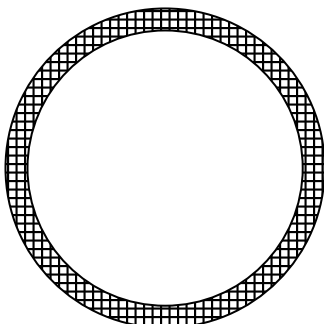

190618 (35mm O-ring) 41 od x 35 id Pipework General

Recommended Spares

Description	Part Number	Qty
Printer Paper	H15746	10
Door Seal (Series 1)	H23270/H24398*	2
PTFE Silicon Grease	C7080	1 Can
Air Filter	60101	2
O Ring - 6mm	190623	10
O Ring - 15mm	190625	10
Tri-Clamp Seal - 1"	H9189	10
PTFE Tri-Clamp Seal - 1.1/2"	H9190	10
Seal Kit for steam inlet valves	DS586	2
Actuator Kit for steam inlet valve	DS 575	2
Seal Kit for Vacuum Valve	DS 589	1
Actuator Kits Vacuum Valve	DS 576	1
Seal Kit - 3/8" SMC Valve	DS 767	2
Spares Kit for Jacket steam Trap	DS 510	2
Push Fit Pneumatic Elbow (1/4"BSP x 4mm)	C4598	5
Fuse 1A	H10010	2
Fuse 2A	H10011	2
Fuse 3.15A	H10388	2
Fuse 5A	H10012	2

*Contact BMM Weston Ltd. to determine appropriate door seal for your machine.

Contacts

The following spare parts are available from BMM Weston;

FOR SPARE PARTS OR SERVICE ASSISTANCE CONTACT BMM SERVICE DIVISION:

Before contacting BMM Weston it would be useful to know

Machine Type	<input type="text"/>
Serial No.	<input type="text"/>
Model No.	<input type="text"/>

BMM SERVICE HELPDESK

BMM Service Department Telephone: **01795 597127**

BMM Service Department Fax: **01795 538891**

BMM Service Department E-mail: service@bmmweston.co.uk

BMM Weston Website: www.bmmweston.com

[Insert GA drawing](#)